



KINETIC ENGINEERING LIMITED

ANNUAL REPORT 2019-2020

Gearing up for the future
We have developed a complete ready-to-fit kit.

Presenting

**ELECTRI
KIT** by Kinetic

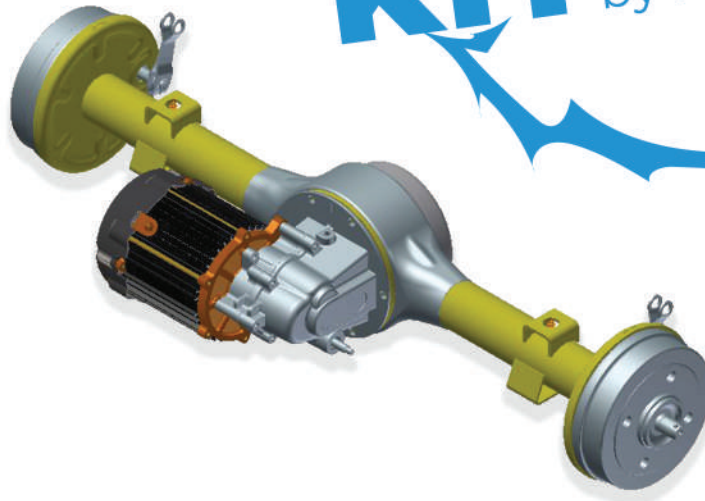

For all types of electric vehicles ranging from 2 wheelers, 3 wheelers and small cars.

The range consists of a single and dual speed rigid axle 1 and 1.2 KW (for e rickshaws); and a 3 to 5KW trans axle (for e auto and small cars) with a self developed gearbox with differential and a special tie up for motors and controllers.

Given our legacy and specialisation, we have also developed a reduction gearbox for electric 2 wheelers.

The kits are 100% made in India

Kinetic hopes to charge up the future with its electrikit range!

BOARD OF DIRECTORS

| | |
|------------------------------|---|
| Mr. Arun Hastimal Firodia | - Chairman |
| Dr. Jayashree Arun Firodia | - Non-Executive Director |
| Ms. Sulajja Firodia Motwani | - Executive Director |
| Mr. Ajinkya Arun Firodia | - Managing Director & Chief Financial Officer |
| Mr. Shirish Ratanlal Kotecha | - Independent Director |
| Mr. Ramesh Jankiram Kabra | - Independent Director |
| Mr. Rohit Prakash Bafana | - Independent Director |
| Mr. Rajiv Ishwarlal Ranka | - Independent Director |

CHIEF EXECUTIVE OFFICER

Mr. Chaitanya Koranne

STATUTORY AUDITOR

M/s. Pawan Jain & Associates,
Chartered Accountants, Pune

COMPANY SECRETARY

Mr. Nikhil Deshpande

SECRETARIAL AUDITOR

M/s Dinesh Birla & Associates
Company Secretaries

REGISTERED OFFICE

D-1 Block, Plot No. 18/2,
MIDC, Chinchwad, Pune - 411019.
Phone no.: + 91-020-66142049
Fax no. + 91-020-66142088/89
E-mail: kelinvestors@kineticindia.com
Website: www.kineticindia.com.

REGISTRAR & TRANSFER AGENT

Link Intime India Private Limited
Block No. 202, Akshay Complex,
Near Ganesh Temple,
Off Dhole Patil Road, Pune – 411001
Phone No.: 020 – 26160084, 26161629,
Tele Fax No.: 020 – 26163503
E-mail Id: pune@linkintime.co.in

WORKS

Nagar-Daund Road,
Ahmednagar, Pin - 414001

CONTENTS

| | |
|---|----|
| • Notice of the Annual General Meeting | 02 |
| • Board's Report Including Management Discussion and Analysis | 10 |
| • Annexures to the Board's Report | 16 |
| • Report on Corporate Governance | 30 |
| • Independent Auditors' Report | 41 |
| • Balance Sheet. | 48 |
| • Statement of Profit and Loss | 49 |
| • Statement of Changes in Equity | 50 |
| • Cash Flow Statement | 51 |
| • Notes to Financial Statements | 52 |

NOTICE

NOTICE is hereby given that the 49th Annual General Meeting of the shareholders of KINETIC ENGINEERING LIMITED will be held on **Wednesday, the 25th day of November, 2020** at 11: 00 a.m., through Video Conferencing ('VC')/Other Audio Visual Means ('OAVM') facility to transact the following business:

ORDINARY BUSINESS:

1. To receive, consider and adopt the Audited Financial Statements for the financial year ended 31st March, 2020, together with the Reports of Auditors and Directors thereon.

SPECIAL BUSINESS:

2. To consider and if thought fit, to pass with or without modifications the following as a **Special Resolution**:

"RESOLVED THAT pursuant to the provisions of Section 152 of the Companies Act, 2013, the applicable provisions of the Securities and Exchange Board of India (Listing Obligations and Disclosure Requirements) Regulations, 2015 (including any statutory modification(s) or re-enactment(s) thereof, for the time being in force), **Dr. Jayashree Arun Firodia (DIN: 00328499)** aged 77 years, who retires by rotation at this meeting and being eligible has offered herself for reappointment, be and is hereby re-appointed as a Non-Executive Director of the Company, liable to retire by rotation."

RESOLVED FURTHER THAT any one of the directors and / or the Company Secretary of the Company be and are hereby severally authorized to do all such acts, deeds or things and to file such requisite forms, papers and other documents with Registrar of Companies, as may be deemed expedient to give effect of the foregoing resolution."

3. To consider and if thought fit, to pass with or without modifications the following as an **Ordinary Resolution**:

"RESOLVED THAT pursuant to the provisions of Sections 149 read with Schedule IV, Section 152 & 161 and other applicable provisions, if any, of the Companies Act, 2013 ("the Act") and the Companies (Appointment and Qualification of Directors) Rules, 2014 and the applicable provisions of the Securities and Exchange Board of India (Listing Obligations and Disclosure Requirements) Regulations, 2015 (including any statutory modification(s) or re-enactment(s) thereof, for the time being in force), **Mr. Jinendra**

Hirachand Munot (DIN: 00049838) who qualifies for being so appointed and who was appointed as an Additional Director at the meeting of the Board of Directors of the Company held on 20th October, 2020 and who holds office up to the date of ensuing Annual General Meeting of the Company and in respect of whom a notice has been received from the member in writing, under Section 160 of the Companies Act, 2013 along with requisite deposit proposing his candidature for the office of director, be and is hereby appointed as the Independent director of the Company, not liable to retire by rotation and to hold office for a period of 5 (five) consecutive years, i.e. upto 19th October, 2025.

RESOLVED FURTHER THAT any one of the directors and / or the Company Secretary of the Company be and are hereby severally authorized to do all such acts, deeds or things and to file such requisite forms, papers and other documents with Registrar of Companies, as may be deemed expedient to give effect of the foregoing resolution."

By Order of the Board of Directors
For **KINETIC ENGINEERING LIMITED**

A. H. Firodia
Chairman

Date: 20th October, 2020 (DIN : 00057324)

Place: Pune.

NOTES:

1. In view of the continuing COVID-19 pandemic, the Ministry of Corporate Affairs ('MCA') has vide its circular dated 5th May, 2020 read with circulars dated 8th April, 2020 and 13th April, 2020 (collectively referred to as 'MCA Circulars') and SEBI circular dated 12th May, 2020 permitted holding of the Annual General Meeting ('AGM') through VC/OAVM facility, without the physical presence of the members at a common venue. In compliance with the provisions of the Companies Act, 2013 (the 'Act'), SEBI (Listing Obligations and Disclosure Requirements) Regulations, 2015 (the 'SEBI Listing Regulations') and MCA Circulars, the AGM of the Company is being conducted through VC/OAVM hereinafter called as 'E-AGM'.

2. Pursuant to the provisions of Section 108 of the Companies Act, 2013 read with Rule 20 of the Companies (Management and Administration) Rules, 2014 (as amended) and Regulation 44 of SEBI (Listing Obligations & Disclosure Requirements) Regulations, 2015 (as amended), and MCA Circulars dated 8th April, 2020 and 13th April, 2020 and 5th May, 2020 the Company is providing facility of remote e-voting to its Members in respect of the business to be transacted at the AGM/EGM. For this purpose, the Company has entered into an agreement with Central Depository Services (India) Limited (CDSL) for facilitating voting through electronic means, as the authorized e-Voting's agency. The facility of casting votes by a member using remote e-voting as well as the e-voting system on the date of the AGM will be provided by CDSL.
3. The attendance of the Members attending the AGM through VC/OAVM will be counted for the purpose of ascertaining the quorum under Section 103 of the Companies Act, 2013.
4. The Members can join the EGM/AGM in the VC/OAVM mode 15 minutes before and after the scheduled time of the commencement of the Meeting by following the procedure mentioned in the Notice. The facility of participation at the EGM/AGM through VC/OAVM will be made available to atleast 1000 members on first come first served basis. This will not include large Shareholders (Shareholders holding 2% or more shareholding), Promoters, Institutional Investors, Directors, Key Managerial Personnel, the Chairpersons of the Audit Committee, Nomination and Remuneration Committee and Stakeholders Relationship Committee, Auditors etc. who are allowed to attend the EGM/AGM without restriction on account of first come first served basis.
5. Pursuant to MCA Circular No. 14/2020 dated 8th April, 2020, the facility to appoint proxy to attend and cast vote for the members is not available for this AGM. However, in pursuance of Section 112 and Section 113 of the Companies Act, 2013, representatives of the members such as the President of India or the Governor of a State or body corporate can attend the AGM through VC/OAVM and cast their votes through e-voting.
6. In line with the Ministry of Corporate Affairs (MCA) Circular No. 17/2020 dated 13th April, 2020, the Notice calling the AGM has been uploaded on the website of the Company at www.kineticindia.com. The Notice can also be accessed from the website of the Stock Exchange i.e. BSE Limited at www.bseindia.com. The AGM Notice is also disseminated on the website of CDSL (agency for providing the Remote e-Voting facility and e-voting system during the AGM i.e. www.evotingindia.com).
7. The AGM is being convened through VC/OAVM in compliance with applicable provisions of the Companies Act, 2013 read with MCA Circular No. 14/2020 dated 8th April, 2020 and MCA Circular No. 17/2020 dated 13th April, 2020 and MCA Circular No. 20/2020 dated 5th May, 2020.
8. Statement pursuant to Section 102 of the Act forms part of this Notice.
9. Brief details of the directors, who are being appointed / re-appointed, are annexed hereto as per requirements of regulation 36(3) of the SEBI Listing Regulations and as per provisions of the Act.
10. Pursuant to the provisions of the Section 91 of the Act, the Register of Members and Share Transfer Books of the Company will remain closed from 19th November, 2020 to 25th November, 2020 (both days are inclusive) for annual closing.
11. Members are requested to:
 - (i) Intimate to the R&T Agent about the changes, if any, in their registered addresses, Dividend mandates etc.
 - (ii) Quote their Folio Number in all their correspondence.
12. Members who have multiple folios with identical order of name are requested to intimate to the R & T Agent about their folios to enable the R & T Agent to consolidate all share holdings into one folio.
13. The Securities Exchange Board of India (SEBI) has mandated the submission of Permanent Account Number (PAN) by every participant in securities market. Members holding shares in electronic form are, therefore, requested to submit the PAN to their Depository Participants with whom they are maintaining their Demat Accounts. Members holding shares in physical form can submit their PAN details to the Company's Registrar and Share Transfer Agents, M/s Link Intime India Private Limited, Mumbai for share transfer process.
14. Pursuant to Section 72 of the Act, Members holding shares in single name are advised to

make a nomination in respect of their shareholding in the Company, in the prescribed Form SH-13. The Nomination Form can be downloaded from the Company's Website. Members holding shares in physical form are advised to file their nomination with the Company's Registrar and Share Transfer Agent, whilst those members holding shares in dematerialised form should file their nomination with their DP.

15. In terms of sections 101 and 136 of the Act, read with the rules made thereunder, the listed companies may send the notice of AGM and the annual report, including financial statements, boards' report, etc. by electronic mode. Pursuant to the said provisions of the Act read with MCA Circulars, SEBI Circular dated 12th May, 2020, Notice of Forty-Ninth (49th) AGM along with the Annual Report for FY 2019-20 is being sent only through electronic mode to those members whose email addresses are registered with the Company/depositories. Members may note that the Notice and Annual Report for FY 2019-20 will also be available on the Company's website at www.kineticindia.com and the website of the stock exchange i.e., BSE Limited at www.bseindia.com.

16. Dematerialisation of Shares:

This is to inform that 87.16 % of the total equity shares have already been dematerialized as of 31st March, 2020. Shareholders who have not dematerialized their shares are requested to get the same dematerialized.

17. Registrar and Share Transfer Agent:

M/s Link Intime India Private Limited, Block No. 202, Akshay Complex, Near Ganesh Temple, Off Dhole Patil Road, Pune – 411001 (Maharashtra, India) is Registrar and Share Transfer Agents. Therefore, the Shareholders of the Company are advised to send all future documents/correspondence such as request for Dematerialisation of Shares, Transfers of Shares, Change of Address, Change of Bank Mandate / ECS and other Share related matters to M/s Link Intime India Private Limited at above mentioned address only.

18. Change of Information/ Bank Mandate:

The members/ shareholders holding shares in physical form are requested to notify/ update any change in their address, Bank Mandate e.g. Name of bank, account number, branch address and ECS number to Registrar and

Share Transfer Agent and/ or the Company or to their respective Depository Participants (DP), if the shares are held in electronic form.

19. INSTRUCTIONS FOR REMOTE E-VOTING AND JOINING THE E-AGM ARE AS FOLLOWS:

(i) Voting Through Electronic Means:

In compliance with the provisions of Section 108 of the Companies Act, 2013 and Rule 20 of the Companies (Management and Administration) Rules, 2014 and Regulation 44 of the SEBI (Listing Obligations & Disclosure Requirements) Regulations, 2015, the Company is pleased to provide members facility to exercise their right to vote at the 49th Annual General Meeting (AGM) by electronic means and the business may be transacted through e-voting services provided by Central Depository Services (India) Limited.

(ii) The instructions for shareholders voting electronically are as under:

- (a) The voting period begins on Sunday, the 22nd November, 2020 at 9.00 A.M. and ends on Tuesday, the 24th November, 2020 at 5.00 P.M. During this period shareholders of the Company holding shares either in physical form or in de-materialized form, as on the cut-off date 18th November, 2020 may cast their vote electronically as well. The e-voting module shall be disabled by CDSL for voting thereafter.
- (b) Shareholders who have already voted prior to the meeting date would not be entitled to vote at the meeting venue.
- (c) The shareholders should log on to the e-voting website www.evotingindia.com.
- (d) Click on "Shareholders" module.
- (e) Now enter your User ID
 - For CDSL: 16 digits beneficiary ID,
 - For NSDL: 8 Character DP ID followed by 8 Digits Client ID,
 - Shareholders holding shares in Physical Form should enter Folio Number registered with the Company.

Or

- Alternatively, if you are registered for CDSL's EASI/EASIEST e-services, you can log-in at <https://www.cdslindia.com> from Login - Myeasi using your login credentials. Once you successfully log-in to CDSL's EASI/EASIEST e-

services, click on e-Voting option and proceed directly to cast your vote electronically.

- (f) Next enter the Image Verification as displayed and Click on Login.
- (g) If you are holding shares in demat form and had logged on to www.evotingindia.com and voted on an earlier e-voting of any company, then your existing password is to be used.
- (h) If you are a first time user follow the steps given below:

For Shareholders holding shares in Demat Form and Physical Form

| | |
|---|--|
| PAN | <p>Enter your 10 digit alpha-numeric *PAN issued by Income Tax Department (Applicable for both demat shareholders as well as physical shareholders)</p> <ul style="list-style-type: none"> • Shareholders who have not updated their PAN with the Company/Depository Participant are requested to use the sequence number which is mentioned in the e-mail sent for sharing notice of AGM and Annual Report indicated in the PAN field. |
| Dividend Bank Details OR Date of Birth (DOB) | <p>Enter the Dividend Bank Details or Date of Birth (in dd/mm/yyyy format) as recorded in your demat account or in the company records in order to login.</p> <ul style="list-style-type: none"> • If both the details are not recorded with the depository or company please enter the member id / folio number in the Dividend Bank details field as mentioned in instruction (v). |

- (i) After entering these details appropriately, click on "SUBMIT" tab.
- (ii) Shareholders holding shares in physical form will then directly reach the Company selection screen. However, shareholders holding shares in demat form will now reach 'Password Creation' menu wherein they are required to mandatorily enter their login password in the new password field. Kindly note that this password is to be also used by the demat holders for voting for resolutions of any other

company on which they are eligible to vote, provided that company opts for e-voting through CDSL platform. It is strongly recommended not to share your password with any other person and take utmost care to keep your password confidential.

- (k) For shareholders holding shares in physical form, the details can be used only for e-voting on the resolutions contained in this Notice.
- (l) Click on the EVSN for the relevant on which you choose to vote.
- (m) On the voting page, you will see "RESOLUTION DESCRIPTION" and against the same the option "YES/NO" for voting. Select the option YES or NO as desired. The option YES implies that you assent to the Resolution and option NO implies that you dissent to the Resolution.
- (n) Click on the "RESOLUTIONS FILE LINK" if you wish to view the entire Resolution details.
- (o) After selecting the resolution, you have decided to vote on, click on "SUBMIT". A confirmation box will be displayed. If you wish to confirm your vote, click on "OK", else to change your vote, click on "CANCEL" and accordingly modify your vote.
- (p) Once you "CONFIRM" your vote on the resolution, you will not be allowed to modify your vote.
- (q) You can also take a print of the votes cast by clicking on "Click here to print" option on the Voting page.
- (r) If a demat account holder has forgotten the login password, then Enter the User ID and the image verification code and click on Forgot Password & enter the details as prompted by the system.
- (s) Shareholders can also cast their vote using CDSL's mobile app "m-Voting". The m-Voting app can be downloaded from respective Store. Please follow the instructions as prompted by the mobile app while Remote Voting on your mobile.

20. PROCESS FOR THOSE SHAREHOLDERS WHOSE EMAIL ADDRESSES ARE NOT REGISTERED WITH THE DEPOSITORIES FOR OBTAINING LOGIN CREDENTIALS FOR E-VOTING FOR THE RESOLUTIONS PROPOSED IN THIS NOTICE:

- (i) For Physical shareholders- please provide necessary details like Folio No., Name of shareholder, scanned copy of the share

certificate (front and back), PAN (self-attested scanned copy of PAN card), AADHAR (self-attested scanned copy of Aadhar Card) by email to **Company/RTA email id**.

- (ii) For Demat shareholders -, please provide Demat account details (CDSL-16-digit beneficiary ID or NSDL-16 digit DPID + CLID), Name, client master or copy of Consolidated Account statement, PAN (self-attested scanned copy of PAN card), AADHAR (self-attested scanned copy of Aadhar Card) to **Company/RTA email id**.
- (iii) The company/RTA shall co-ordinate with CDSL and provide the login credentials to the above mentioned shareholders.

21. INSTRUCTIONS FOR SHAREHOLDERS ATTENDING THE AGM THROUGH VC/OAVM ARE AS UNDER:

- (i) Shareholder will be provided with a facility to attend the AGM through VC/OAVM through the CDSL e-Voting system. Shareholders may access the same at <https://www.evotingindia.com> under shareholders/members login by using the remote e-voting credentials. The link for VC/OAVM will be available in shareholder/members login where the EVSN of Company will be displayed.
- (ii) Shareholders are encouraged to join the Meeting through Laptops / IPads for better experience.
- (iii) Further shareholders will be required to allow Camera and use Internet with a good speed to avoid any disturbance during the meeting.
- (iv) Please note that Participants Connecting from Mobile Devices or Tablets or through Laptop connecting via Mobile Hotspot may experience Audio/Video loss due to Fluctuation in their respective network. It is therefore recommended to use Stable WiFi or LAN Connection to mitigate any kind of aforesaid glitches.
- (v) Shareholders who would like to express their views/ask questions during the meeting may register themselves as a speaker by sending their request in advance atleast 7 days prior to meeting mentioning their name, demat account number/folio number, email id, mobile number at kelinvestors@kineticindia.com. The shareholders who do not wish to speak during the AGM but have queries may send their queries in advance 3 days prior to meeting

mentioning their name, demat account number/ folio number, email id, mobile number at kelinvestors@kineticindia.com. These queries will be replied to by the company suitably by email on kelinvestors@kineticindia.com.

- (vi) Those shareholders who have registered themselves as a speaker will only be allowed to express their views/ask questions during the meeting.

22. INSTRUCTIONS FOR SHAREHOLDERS FOR E-VOTING DURING THE AGM ARE AS UNDER:

- (i) The procedure for e-Voting on the day of the AGM same as the instructions mentioned above for Remote e-voting.
- (ii) Only those shareholders, who are present in the AGM through VC/OAVM facility and have not casted their vote on the Resolutions through remote e-Voting and are otherwise not barred from doing so, shall be eligible to vote through e-Voting system available during the AGM.
- (iii) If any Votes are cast by the shareholders through the e-voting available during the AGM and if the same shareholders have not participated in the meeting through VC/ OAVM facility, then the votes cast by such shareholders shall be considered invalid as the facility of e-voting during the meeting is available only to the shareholders attending the meeting.
- (iv) Shareholders who have voted through Remote e-Voting will be eligible to attend the AGM. However, they will not be eligible to vote at the AGM.

23. NOTE FOR NON - INDIVIDUAL SHAREHOLDERS AND CUSTODIANS:

- (i) Non-Individual shareholders (i.e. other than Individuals, HUF, and NRI etc.) and Custodians are required to log on to www.evotingindia.com and register themselves in the "Corporates" module.
- (ii) A scanned copy of the Registration Form bearing the stamp and sign of the entity should be emailed to helpdesk.evoting@cdslindia.com.
- (iii) After receiving the login details a Compliance User should be created using the admin login and password. The Compliance User would be able to link the account(s) for which they wish to vote on.
- (iv) The list of accounts linked in the login should be mailed to helpdesk.evoting@cdslindia.com

and on approval of the accounts they would be able to cast their vote.

- (v) A scanned copy of the Board Resolution and Power of Attorney (POA) which they have issued in favour of the Custodian, if any, should be uploaded in PDF format in the system for the scrutinizer to verify the same.
- (vi) Alternatively Non Individual shareholders are required to send the relevant Board Resolution/ Authority letter etc. together with attested specimen signature of the duly authorized signatory who are authorized to vote, to the Scrutinizer and to the Company at the email address viz; kelinvestors@kineticindia.com if they have voted from individual tab & not uploaded same in the CDSL e-voting system for the scrutinizer to verify the same.
- (vii) If you have any queries or issues regarding attending AGM & e-Voting from the e-Voting System, you may refer the Frequently Asked Questions ("FAQs") and e-voting manual available at www.evotingindia.com, under help section or write an email to helpdesk.evoting@cdslindia.com or contact Mr. Nitin Kunder (022-23058738) or Mr. Mehboob Lakhani (022-23058543) or Mr. Rakesh Dalvi (022-23058542).

All grievances connected with the facility for voting by electronic means may be addressed to Mr. Rakesh Dalvi, Manager, (CDSL) Central Depository Services (India) Limited, A Wing, 25th Floor, Marathon Futurex, Mafatlal Mill Compounds, N M Joshi Marg, Lower Parel (East), Mumbai - 400013 or send an email to helpdesk.evoting@cdslindia.com or call on 022-23058542/43.

24. GENERAL INSTRUCTIONS:

- (i) The Board of Directors have appointed M/s Dinesh Birla & Associates as the Scrutiniser to the e-voting process, and voting at the e-AGM in a fair and transparent manner.
- (ii) The Chairman shall formally propose to the members participating through VC/OAVM facility to vote on the resolutions as set out in the Notice of the Forty Ninth eAGM and announce the start of the casting of vote through the e-voting system of CDSL.
- (iii) The Scrutinizer shall, immediately after the conclusion of voting at the e-AGM, first count the votes cast at the meeting, thereafter unblock the votes through e-voting and make a

consolidated Scrutinizers' report of the total votes cast in favor or against, if any, to the Chairman who shall countersign the same.

- (iv) The scrutinizer shall submit his report to the Chairman as the case may be, who shall declare the result of the voting. The results declared along with the scrutinizer's report shall be placed on the Company's website and shall also be communicated to the stock exchanges. The resolutions shall be deemed to be passed at the e-AGM of the Company.
- 25. The Scrutinizer shall make, not later than 48 hours of the conclusion of the AGM, a consolidated Scrutinizer's Report of the total votes cast in favour or against, if any, to the Chairman / person of the Meeting or a person authorized by him / her in writing, who shall countersign the same and declare the results of the voting forthwith.
- 26. The Results declared along with the Report of the Scrutinizer shall be placed on the website of the Company at www.kineticindia.com, on the website of BSE at www.bseindia.com and also on the website of CDSL at www.evotingindia.com immediately after the declaration of result by the Chairman / person of the Meeting or the person authorized by him / her in writing.
- 27. On receipt of the requisite number of votes, the Resolutions shall be deemed to have been passed on the date of the Annual General Meeting.

By Order of the Board of Directors
For **KINETIC ENGINEERING LIMITED**

A. H. Firodia
Chairman

Date: 20th October, 2020 (DIN : 00057324)
Place: Pune.

*Members are requested to support the "Green Initiative" by registering their email address with the Registrar & Share Transfer Agent (RTA)/Company, if not already done.

As required by Section 102 of the Companies Act, 2013 (the “Act”), the following Explanatory Statement sets out all material facts relating to the business mentioned under Item no. 2 & 3 of the accompanying Notice dated 20th October, 2020.

Item No. 2: Re-appointment of Dr. Jayashree Arun Firodia as Non-Executive Director

As per Regulation 17(1A) of the SEBI (Listing Obligations and Disclosure Requirements) Regulations, 2015 (hereinafter referred to as ‘Listing Regulations’) as amended vide SEBI (Listing Obligations and Disclosure Requirements) (Amendment) Regulations, 2018, with effect from 1st April, 2019, no listed Company shall appoint or continue the Directorship of a Non-Executive Director who has attained the age of 75 years, unless a Special Resolution is passed to that effect and justification thereof is indicated in the explanatory statement annexed to the Notice for such appointment.

The Board hereby recommends for the reappointment of **Dr. Jayashree Arun Firodia** (DIN: 00328499) aged 77 years, as Non-Executive Director of the Company who will retire by rotation.

The Board of Directors is of the opinion that Dr. Jayashree Arun Firodia is a person of integrity; possess relevant expertise and vast experience. Her association as Non-executive director will be beneficial and in the best interest of the Company. The brief resume of said Director as required under Regulation 36(3) of the SEBI (Listing Obligations and Disclosure Requirements) Regulations, 2015 as amended is set out in this Notice as Annexure A.

The Board of Directors accordingly recommends the Special Resolution as mentioned in item no. 2 of this Notice for approval of the Members of the Company.

Mr. Arun H. Firodia, Dr. Jayashree A. Firodia, Ms. Sulajja Firodia Motwani and Mr. Ajinkya Firodia may be deemed to be interested, financially or otherwise, in the resolution as set out at Item No. 2 of the Notice.

Except these, none of the other Directors and Key Managerial Personnel are deemed to be concerned or interested, financially or otherwise in the proposed Special Resolution.

Item No. 3: Appointment of Mr. Jinendra Hirachand Munot as Independent Director

The Board, at its meeting held on 20th October, 2020 appointed **Mr. Jinendra Hirachand Munot** (DIN: 00049838) as Independent Director

(Additional) of the Company, pursuant to Section 161 of the Companies Act, 2013. The Company has also received (i) consent in writing from **Mr. Jinendra Hirachand Munot** to act as Director in Form DIR 2 pursuant to Rule 8 of the Companies (Appointment & Qualification of Directors) Rules, 2014 (‘Appointment Rules’), (ii) intimation in Form DIR 8 in terms of the Appointment Rules from **Mr. Jinendra Hirachand Munot** to the effect that he is not disqualified under sub-section (2) of Section 164 of the Act, and (iii) a declaration to the effect that he meets the criteria of independence as provided in subsection (6) of Section 149 of the Act.

Mr. Jinendra Hirachand Munot is having more than 40 years of rich experience in Automotive and allied industries and General Management. In the opinion of the Board, **Mr. Jinendra Hirachand Munot** fulfils the conditions for independence specified in the Act, the Rules made thereunder and the SEBI (Listing Obligations and Disclosure Requirements) Regulations, 2015. A copy of the draft letter for his appointment as an Independent Director setting out the terms and conditions shall be made available for inspection, without any fee, by the members at the Company’s registered office during normal business hours on working days.

The brief resume of said Director as required under Regulation 36(3) of the SEBI (Listing Obligations and Disclosure Requirements) Regulations, 2015 as amended is set out in this Notice as Annexure A.

The resolution seeks the approval of members for the appointment of **Mr. Jinendra Hirachand Munot** as an Independent Director of the Company for a period of five years up to 19th October, 2025 pursuant to Sections 149, 152 and other applicable provisions of the Act and the Rules made thereunder (including any statutory modification(s) or re-enactment(s) thereof) and he shall not be liable to retire by rotation.

No Director, Key Managerial Personnel or their relatives except **Mr. Jinendra Hirachand Munot** whom the resolution relates, is interested in or concerned with the resolution in Item No. 3.

Your Board recommends the resolution set forth in Item No. 3 for the approval of the members by **Ordinary Resolution**.

Annexure - A

“Details of Directors seeking appointment/ re-appointment at the Annual General Meeting [In pursuance of Corporate Governance provision of Listing Regulations, 2015]”

| Name of the Director | Dr. Jayashree Arun Firodia | Mr. Jinendra Hirachand Munot |
|--|---|---|
| Date of Birth (Age) | 26 th January, 1943 (77 years) | 04 th August, 1952 (68 years) |
| DIN | 00328499 | 00049838 |
| Date of Appointment | 27/10/2017 | 20/10/2020 |
| Qualification | M.B.B.S., D. Ch. University of London USA, AMIE (India) | B.E. (Mech.), MS (Mech.) |
| Directorship as on 31 st March, 2020 | Kinetic Green Energy and Power Solutions Ltd., Kinetic Auto Ltd., Motoroyale Kinetic Pvt. Ltd., Ajinkya Auto Fab Ltd., Kinetic Hyundai Elevator and Movement Technologies Ltd., MV Agusta India Pvt. Ltd. and Children S Future India Pvt. Ltd. | Varsha Forgings Ltd. |
| Chairmanship/Membership of Committees of other Companies as on 31 st March, 2020. | Nil | Nil |
| Shareholding in the Company | 34,75,222 | 28,712 |
| Brief profile | An eminent Pediatrician from Pune. She has completed her M.B.B.S. in first class from B J Medical College, Pune in 1966 and D. Ch. from University of London in 1970. She has a rich experience of over 40 years in Medical Science as a Pediatrician and General Management. Currently, she is an active member of the Board of Directors of various Kinetic Group companies and designated as Promoter Director in Kinetic Engineering Ltd. | B.E.(Mech.), M.S.(Mech.) U.S.A, AMIE (India). Mr. Jinendra Munot is a Professional Engineer over 42 years of experience in the Automotive Industries. He was last designated as Joint Managing Director of ZF Steering Gear (India) Ltd.He won the ‘India’s Champion Corporate Golfer’ organised by the DS Group- Economic Times Leaders Challenge Tour, during the year 2008-09. |

BOARD'S REPORT 2019-20
(Including Management Discussion & Analysis)

Dear Members,

Your Directors present the 49th Annual Report on the business and operations of **Kinetic Engineering Limited** and the Audited Financial Statements for the financial year ended 31st March, 2020.

last year were marginally lower at INR 118.5 Crores as against an expectation of INR 130 Crores.

I. Financial Performance:

(INR in Lakhs)

| Particulars | 31 st March, 2020 | 31 st March, 2019 |
|--|------------------------------|------------------------------|
| Total Revenue | 11,849.86 | 12,376.69 |
| Profit/ (Loss) before Interest, Depreciation, Tax and other Amortizations ("EBIDTA") | 469.90 | 516.27 |
| Less : Depreciation and Amortization Expenses | 721.26 | 734.41 |
| Finance Cost | 660.38 | 598.22 |
| Tax Expenses – Net | - | - |
| Profit/(Loss) for the year | (911.74) | (816.36) |
| Other Comprehensive Income | (30.71) | (64.83) |
| Total Comprehensive Income/(loss) for the year | (942.45) | (881.29) |

Dividend:

No dividend is recommended in view of the loss during the period under review.

II. Business:

Your Company has recorded a nearly flat revenue of INR 118.5 Crores in the FY 2019 – 20 compared to a revenue of INR 120.5 Crores for the previous year. The company had continued to grow compared to last year, as was evident by the revenue of INR 92 Crores clocked by the company for the first 3 quarters ended in December, 2019 compared to INR 82 Crores for the corresponding three quarters ended December, 2018, a growth of nearly 10%. The growth was unfortunately abruptly halted due to loss of last 9 days due to the nationwide and worldwide lockdown due to the CoVID – 19 Pandemic and the government regulations thereof. Due to this lockdown, the sales in the

**REVENUE OVER 5 YEARS
(INR IN LAKHS) REVENUE**

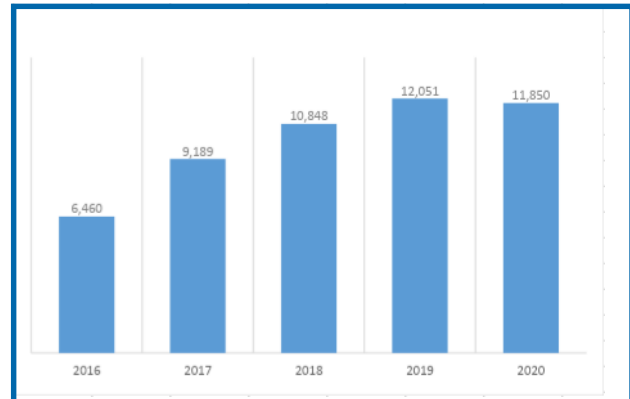

The recorded growth rate was despite of slowdown of economic growth across sectors in the automobile market, and led by our strategy to focus on exports with stable large volume growing businesses. The new businesses also stabilized and continued the steady demand throughout the year. The value of exports as a proportion to the total revenue increased to 50% from 45% in the previous year.

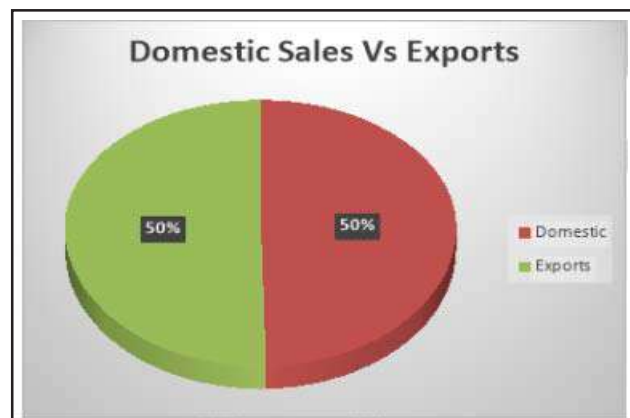

Commodity prices continued to grow this year, as per the continued trend in the market. Your company took various actions, including in sourcing, price increases, negotiations, and others to reduce material cost by 2% despite the same. However, due to the lockdown imposed in the last 9 days of the year, the EBDITA margin dropped slightly to 3.97% from 4.28% the previous year due to lost contribution.



We are hopeful of a recovery in the market in the coming months and years, once the tide, impact and severity of the virus has reduced.

New products and Capital expenditure:

The company believes that the electric vehicle segment shall grow in times to come, at a rapid pace. In order to prepare for the green future, your Company has strategically developed and entered into manufacture of powertrain for the Electric vehicles during the year under review. The powertrain includes complete axle, with gearbox with a range spanning from 1, 1.2, 3 to 5 kw sets for electric rickshaws and e-autos. These products will be 100% Made in India and shall cater to the largest market in the electric segment as a complete kit for the current OEMs. The development of these kits are successfully completed. The Company continues its focus and investment in R&D and upgradation of machinery as required to meet the high quality demands of customers and innovation that lies in our DNA.

Operations:

The company continued its growth plan in the coming year, until the CoVID 19 pandemic and sudden halt. It also made efforts for reduction in manpower and other costs in order to achieve profitability. The current year has witnessed a slowdown in the domestic Automotive and Commercial Vehicles business. As a result, the domestic sale for the company's products was nearly 25% lower compared to the previous year. However, the export sale increased from INR 40 Crores to INR 53.5 Crores helping the company to maintain its revenue in spite of very tough domestic situation.

Employee Relations:

The Company has implemented regular training modules for its employees through internal and external faculties for developing and maintaining a better skilled work force and it has maintained cordial labour relations throughout the year.

Management Discussion and Analysis:

The Company is mainly supplying assemblies and components for the Medium & Heavy Commercial Vehicles, Automotive and Tractor industry. The company is also exporting nearly 50% of its products, either directly or indirectly (through its customers in

India). Therefore, global economic scenario as well as domestic economic policies impacts the business.

Domestic economy has grown by 4.2% in FY20, which has been one of the lowest in the current series. The GDP growth quarter on quarter has been low despite reasonably good monsoon. Automotive and Commercial vehicle sectors have been some of the most affected sectors in the year under review compared to the previous year.

The sale of passenger vehicles in the domestic market has shown a decline of nearly 20% in FY2019-20 compared to FY2018-19. However, the export of passenger vehicles remained stagnant as per the data published by SIAM.

The Commercial Vehicles however, has reported a massive decline of 30% in the domestic market and nearly 40% in the export market. This was in line with the overall slowdown in the economic activity in the economy. The tractor segment has maintained its momentum.

The tractor market, which is also a major segment to which the company supplies its products, declined by about 12% from a level of 878,476 nos. during FY2018-19 to 781,065 nos. in the FY2019-20.

The CoVID-19 situation in the current financial year has significantly affected the outlook in the domestic market, though signs of recovery owing to good monsoon and beginning of festive season are now clearly visible. With further opening up of the economic activities, the company expects that it will reach the level of normal activity only by the fourth quarter of the current financial year.

Risks and Opportunities:

Market Risks:

The CoVID-19 situation continues to impact operations of many of our customers. Second wave of the pandemic may significantly impact the fragile recovery. Increasing geopolitical tensions between the largest economies in the world and India's neighbours may affect plans of our customers, thereby affecting demand for our products.

On the contrary, pent up demand and good monsoon seems to be driving quick economic recovery. We believe this trend will continue in the coming quarters.

The company is investing in new products in the emerging segment of electric mobility, which will help the company to reduce such impact in the years to come.

Raw Material Risks:

Even though the commodity prices have been stable for most of the last year and till now, with increasing demand, steel suppliers may again resort to price increases in a collective manner to offset the losses incurred.

The company is in continuous discussion with steel suppliers and also adding new suppliers to ensure smooth supplies of steel.

Government Policy Risks:

The Government has been evaluating relaxing the maximum load carrying limit for commercial vehicles along with maximum life requirement. In the short term it may impact the demand for commercial vehicles. However, the company supplies products to a niche segment of School Buses which is unlikely to get impacted due to the policy change.

Opportunities:

With increasing geopolitical tensions between the largest economies of the world, there is likely to be a shift in the supply chain. This will open up good opportunities for resourcing of components from India. The company will benefit hugely due to this as the company already has a presence in the global supply chains of major automotive companies. The company is also in discussions with a large Tier 1 manufacturer for export of components to the parent company.

The Government is also considering scrappage policy for older vehicles as announced by the Honourable Minister for Road and Surface Transport, Shri. Nitin Gadkari. This is expected to give a big boost to automobile as well as Commercial vehicles, which will greatly benefit the company. The company is fully geared-up to exploit the opportunities arising from the above.

The company has already finalized a contract for additional volumes for components being presently supplied to Renault, which will result in additional revenue of INR 5 Crores p.a. However, the business will materialize once the situation starts to return to normal, post COVID.

New business from American Axle, which was ramped up in the last quarter of FY19, is also likely to demand higher quantities in the current year. This will benefit the company to generate additional export revenue.

The company has already developed three different versions of powertrain for electric three wheelers and started supplying the same to its sister company, Kinetic Green. The company is also in discussion with a large and reputed motor and controller manufacturer for a joint marketing of each other’s products as a complete solution giving better value to the potential customers. Several samples have already been given to various customers and the company expects good volumes to materialize. Given the push by the Government to Make-In-India and to Electric Mobility, the company sees a very good opportunity to develop and sell products in the Electric Mobility space.

Given the current market outlook and opportunities opening up and the initiatives taken by the Management, the Company is hopeful of a bright future in the coming years.

III. Corporate Governance

A Report on Corporate Governance along with a Certificate from the Statutory Auditors of the Company regarding compliance with the conditions of Corporate Governance as stipulated under the provision of Listing Regulations, 2015 forms part of the Annual Report.

Board of Directors

Board’s Composition and Independence

As on 31st March, 2020, our Board comprised of eight members, headed by a Non- Executive Chairman, two Executive Directors and five Non-Executive Directors where in four are Independent Directors. Two out of eight members are Women Directors. The composition of the Board is in accordance with the requirements of the Listing Regulations, 2015 & the Companies Act, 2013.

The Company has received necessary declarations from the Independent Directors stating that they meet the prescribed criteria for independence.

Directors and Key Managerial Personnel (KMP) Directors

Mr. Rajiv Ishwarlal Ranka (DIN: 00392438) resigned from the position of the “Non-Executive Independent Director” of the Company with effect from 07th September, 2020 due to increase in his professional pre-occupancies. He further confirmed that there is no other material reason behind his resignation.

Further, to fill the vacancy caused due to resignation of Mr. Rajiv Ishwarlal Ranka, the Board at its meeting held on 20th October, 2020, has inducted Mr. Jinendra Hirachand Munot (DIN: 00049838) as an Additional Director in the capacity of Independent Director on the Board of the Company, for a term of 5 years effective from 20th October, 2020 to 19th October, 2025, subject to shareholders’ approval at the ensuing Annual General Meeting. In accordance with Section 160 of the Companies Act, 2013, the Company has received notice proposing his candidature for the office of Independent Director.

Dr. Jayashree Arun Firodia, Director of the Company, retires by rotation at the ensuing Annual General Meeting, and being eligible offers herself for re-appointment.

Key Managerial Personnel (KMP)

During the year under review, following changes occurred in the Key Managerial Personnel of the Company:

| Sr. No. | Name of the KMP | Nature of Change | Date | Category |
|---------|----------------------|---------------------------|---------------------------------|-------------------|
| 1 | Ms. Deepal Shah | Ceased due to resignation | 03 rd June, 2019 | Company Secretary |
| 2 | Mr. Nikhil Deshpande | Appointment | 15 th November, 2019 | Company Secretary |

Board Meetings

The Board met Five times during the financial year 2019-20 i.e. 29th May 2019; 17th July, 2019; 14th August, 2019; 14th November, 2019; and 13th February, 2020. The maximum interval between any two meetings did not exceed 120 days.

Audit Committee

All the Committee members are Non-Executive Independent Directors. All the Members of the Committee possess sufficient accounting and financial management knowledge. The Company Secretary of the Company is the Secretary of the Committees also. The recommendations of the Audit Committee during the year were accepted by the Board.

Board Evaluation

Pursuant to the provisions of the Companies Act, 2013 and Listing Regulations, 2015, Independent Directors at their discussion, without the participation of the Non-Independent Directors and Management, evaluated the Boards' performance, Performance of the Chairman and other Non-Independent Directors.

The Board subsequently evaluated its own performance, the working of its Committees (Audit, Nomination and Remuneration and Stakeholders Relationship Committee) and Independent Directors (without participation of the relevant Director).

Remuneration Policy of the Company

The Remuneration policy of the Company comprising of the appointment and remuneration of the Directors, Key Managerial Personnel and Senior Executives of the Company including criteria for determining qualifications, positive attributes, independence of the Directors and other related matters has been framed by Nomination and Remuneration Committee and has been briefed in Annexure-III to this Report.

Vigil Mechanism

The Vigil Mechanism as envisaged in the Companies Act, 2013, the Rules prescribed thereunder and the Listing Regulations, 2015, is implemented through the Company's Whistle Blower Policy to enable the Directors and employees of the Company to report genuine concerns, to provide for adequate safeguards against victimization of persons who use such mechanism and make provision for direct access to the Chairman of the Audit Committee.

Whistle Blower Policy of the Company is available on the Company's website at www.kineticindia.com/investors.

Information required under Sexual Harassment of Women at Work place

The Company has in place, the requisite Internal Committee as envisaged in the Sexual Harassment of

Women at Workplace (Prevention, Prohibition and Redressal) Act, 2013. No complaints on the issues covered by the above Act were received, during the year.

Contracts or Arrangements with Related Parties

As required under the Listing Regulations, 2015, Related party transactions are placed before the Audit Committee for approval. At the beginning of the financial year, prior approval of the Audit Committee is obtained on an omnibus basis for continual transactions. The corresponding actual transactions then become a subject of review by the Committee at subsequent meetings.

All related party transactions/arrangements entered into by the Company during the year, were on an arm's length basis and in ordinary course of business.

There was no materially significant related party transactions entered into by the Company with the Promoters, Directors, Key Managerial Personnel or other designated persons which could conflict with the interest of the Company as a whole. Consequently, disclosures in Form AOC-2 pursuant to Rule 8 (2) of the Companies (Accounts) Rules, 2014 are not required.

The policy on Related Party Transactions as approved by the Board is available on the Company's website at www.kineticindia.com/investors.

Particulars of Loans, Guarantees or Investments under Section 186 of the Companies Act, 2013

Details of Loans, Guarantees and Investments covered under the provisions of Section 186 of the Companies Act, 2013 are given in Note 4 & 5 of Notes to the Financial Statements.

Directors' Responsibility Statement

Pursuant to Section 134(5) of the Companies Act, 2013, your Directors, based on the representations received from the Operating Management, and after due enquiry, confirm that:

- (a) In the preparation of the annual accounts for the Financial Year ended 31st March, 2020, the applicable accounting standards have been followed along with proper explanation relating to material departures;
- (b) The Directors had in consultation with Statutory Auditors, selected accounting policies and applied them consistently and made judgments and estimates that are reasonable and prudent so as to give a true and fair view of the state of affairs of the Company as at 31st March, 2020 and of the Loss of the Company for the year ended on that date;
- (c) The Directors have taken proper and sufficient care for the maintenance of adequate accounting records in accordance with the provisions of the Companies Act, 2013 for safeguarding the assets

of the Company and for preventing and detecting fraud and irregularities;

- (d) The Directors have prepared the annual accounts on a going concern basis;
- (e) The Directors have laid down adequate Internal Financial Controls to be followed by the Company and such Internal Financial Controls were operating effectively during the Financial Year ended 31st March, 2020;
- (f) The Directors had devised proper systems to ensure compliance with the provisions of all applicable laws and that such systems were adequate and operating effectively throughout the Financial Year ended 31st March, 2020.

Particulars of Employees and related disclosures:

In terms of the provisions of Section 197(12) of the Companies Act, 2013 read with Rules 5(2) and 5(3) of the Companies (Appointment and Remuneration of Managerial Personnel) Rules, 2014, there are no employees drawing remuneration in excess of the limits set out in the said Rules.

Disclosures pertaining to remuneration and other details as required under Section 197(12) of the Companies Act, 2013 read with Rule 5(1) of the Companies (Appointment and Remuneration of Managerial Personnel) Rules, 2014 are provided in Annexure V of the Annual Report.

Having regard to the provisions of Section 136(1) read with its relevant provision of the Companies Act, 2013, the Annual Report excluding the aforesaid information is being sent to the members of the Company. The said information is available for inspection at the Registered Office of the Company during working hours and any member interested in obtaining such information may write to the Company Secretary and the same will be furnished without any fee.

IV. Audit and Internal Financial Control

Statutory Auditor

The members of the Company had approved the appointment of M/s Pawan Jain & Associates (FRN0107867W) Chartered Accountants, Pune to hold office for five years until the conclusion of Annual General Meeting to be held in the calendar year 2022 in accordance with the provisions of Section 139 of the Companies Act, 2013. However, as per amended Companies (Audit and Auditors) (Amendment) Rules, 2018, the requirement of ratification of appointment of auditors in subsequent general meetings has been done away with.

Auditors' Report

There are no qualifications, reservations or adverse remarks made by M/s Pawan Jain & Associates,

Statutory Auditors, in their report for the financial year ended 31st March, 2020.

Pursuant to the provisions of Section 143(12) of the Companies Act, 2013, the statutory auditors have not reported any incident of fraud to the Audit Committee during the year under review.

Secretarial Audit – FY 2019-20

Mr. Dinesh Birla, proprietor of Dinesh Birla and Associates, Practicing Company Secretaries was appointed by the Board to conduct the audit of the Company's Secretarial Records in respect of the financial year 2019-20.

The report of the Secretarial Audit appears as Annexure – IV to this Report. There are no qualifications in the Report.

Secretarial Auditor – FY 2020-21

Pursuant to the provisions of Section 204 of the Companies Act, 2013 and the Companies (Appointment and Remuneration of Managerial Personnel) Rules, 2014, the Company has appointed Mr. Dinesh Birla, Practicing Company Secretary (Certificate of Practice No.: 13029) to undertake the Secretarial Audit of the Company for the financial year 2020-21.

Internal Control System and their adequacy

The Company has adequate internal control system commensurate with its size and nature of business for ensuring efficiency of operations, adherence to management policies and protection of company's assets. The Company's Audit Committee periodically reviews the internal control systems and compliance with Company's policies, procedures and laws.

V. Other Disclosures

Postal Ballot:

There was no Postal Ballot conducted during the financial year under review.

Deposits:

During the year under review, your Company had not accepted any deposits within the meaning of provisions of Chapter V – Acceptance of Deposits by Companies of the Companies Act, 2013 read with the Companies (Acceptance of Deposits) Rules, 2014.

Conservation of Energy, Technology Absorption and Foreign Exchange Earnings and Outgo:

The information pertaining to conservation of energy, technology absorption, foreign exchange earnings and outgo as required under section 134(3)(m) of the Companies Act, 2013 read with Rule 8(3) of the Companies (Accounts) Rules, 2014 is furnished as Annexure I to this Report.

Extract of Annual Return:

Pursuant to section 134 and section 92 of the Companies Act, 2013 read with Rule 12 (1) of the Companies (Management and Administration) Rules, 2014, an extract of the Annual Return as on 31st March, 2020 in Form No. MGT- 9 is attached herewith as Annexure II and forms part of this Report. It is also available on the website of the Company at www.kineticindia.com.

Material changes and commitments between the end of the Financial year and Date of Report:

There have been no material changes and commitments affecting the financial position of the Company between the end of financial year and the date of the Report.

Cautionary Statement

The report contains estimates and expectations, which could be 'forward looking'. Actual results, however, might differ from estimates and expectations expressed or implied in this report, as the same are affected by many other uncertainties, including raw material availability & prices, changes in Government

regulations, tax regimes, economic developments and other incidental factors.

Significant and Material Orders Passed by the Regulators or Courts or Tribunals impacting the Going Concern Status of the Company

There are no significant and material orders passed by the Regulators or Courts or Tribunals which would impact the Going Concern Status of the Company.

Acknowledgement

The Directors' express their sincere thanks to Central & State Governments, Financial Institutions, banks who have extended their support in form of Credit Facilities, suppliers and stakeholders for the support extended to the Company and also wish to place on record their appreciation of the dedicated services rendered by the employees of the Company.

On behalf of the Board of Directors
For Kinetic Engineering Limited

A. H. Firodia
Chairman

Date: 20th October, 2020 **(DIN : 00057324)**
Place: Pune.

Annexure - I
**CONSERVATION OF ENERGY, TECHNOLOGY ABSORPTION
AND FOREIGN EXCHANGE EARNINGS AND OUTGO**

[Section 134(3)(m) of the Companies Act, 2013 read with Rule 8(3) of the Companies (Accounts) Rules, 2014]

A) Conservation of energy:

1. Details of steps taken for conserving electrical energy during the previous year under review:

- i) Maintaining unity power factor throughout year saving **INR 23,99,155/-** as an Incentive in electricity bills.
- ii) Machine reshifting as per layout to save transportation of jobs from one shop to another shop and better control of energy consumption.
- iii) Street light (LED) replaced 14 nos. instead of 250 watts Result in 329 unit saving per year.
- iv) Energy efficient (Fluorescent tube fitting 72W) 20 nos. installed in Hall. No. 11, instead of 250watt mercury lamps. Result in 513 units saving per year.
- v) On shut down or paid holidays load is diverted on two transformers instead of five and remaining transformer shut off saving unwanted losses and power. As well as during lockdown period resulted in to 36,500 units saving per year.
- vi) In Hall No. 10, 9, 9A, 8, 28 and 30 machine shop idle running of high consumption machines stopped by auto time introduction saving 35,000 units per year.
- vii) In Hall No. 10, 9, 9A, 8, 28 and 30 electronic control machine fitted MCB incoming supply line. To cut off power of stabilizer and idle transformer, In result of saving 18,540 units per year.
- viii) For waste water treatment plant 50 lack litres treated water is used for gardening.

2. Annual saving due to above steps in term of KWH and INR:

Annual unit saving **90,882** units. (**INR 8,46,111/-** @ **INR 9.31/-** Units) and P.F. Incentive **INR 23,99,155/-** Lacks Total **INR 32,45,266/-** Saved.

- 1) Steps taken by the Company for utilizing alternative sources of energy: **Nil**
- 2) Capital Investment in energy conservation: **Nil**

B) Technology Absorption

I) The efforts made towards technology absorption:

1. Development of Rigid axle for electric three/ four wheelers. - Single speed- import substitute.
2. Development of 2 speed Rigid axle and gear box.
3. Up gradation of 320 Nm transmission to 380 Nm capacity.
4. Build new 2 way SPM for angular milling for Spline Yoke to improve balancing in assembly.
5. In-house build End of Line test rig for Rigid axle.

6. In-house build endurance test rig for rigid axle.
 7. Development of leaner and rotary welding SPM for Axle Body.
 8. Build in-house two way boring SPM for Axle Body.
 9. Adoption of poka-yoka on induction hardening machine to avoid part burn.
- II) Benefits derived as a result of the above efforts:
- a. Development of import substitute for transmissions used in Electric Vehicles.
 - b. Upgradation of existing transmissions for higher capacity.
 - c. Savings on capital investments by developing in machinery.
 - d. Reduction in foreign exchange outgo
 - e. Improvements in Manufacturing methods and quality standards.
 - f. Aiming towards self sufficiency in engineering skills for manufacturing range of steering gears and connected products.
 - g. Development of cost effective, high performance engineering products.
 - h. Meet customer demands.
- III) In case of imported technology (imported during the last three years reckoned from the beginning of the financial year)- **Nil**
- IV) The Expenditure incurred on Research and Development: INR 1.62 Crores (Previous Year INR 1.55 Crores)

C) Foreign Exchange Earnings and Outgo:

The Company continues to strive to improve its export earnings. The information on foreign exchange earnings and outgo for the year under review are as under:

| Sl. No. | Particulars | INR in Lakhs |
|---------|--|--------------|
| 1 | Total foreign exchange earned in terms of actual inflows | 5,235.10 |
| 2 | Total foreign exchange outgo in terms of actual outflows | 75.35 |

On behalf of the Board of Directors
For, Kinetic Engineering Limited

A. H. Firodia
Chairman

Date: 20th October, 2020 (DIN : 00057324)

Place: Pune.

ANNEXURE -II
Form No. MGT-9
EXTRACT OF ANNUAL RETURN
As on the financial year ended on 31st March, 2020

[Pursuant to Section 92(3) of the Companies Act, 2013 and Rule 12(1) of the Companies (Management and Administration) Rules, 2014]

I. REGISTRATION AND OTHER DETAILS:

| | | |
|------|---|---|
| i) | CIN | L35912MH1970PLC014819 |
| ii) | Registration Date | 08/10/1970 |
| iii) | Name of the Company | Kinetic Engineering Limited |
| iv) | Category / Sub-Category of the Company | Limited Company / Limited by Shares |
| v) | Address of the Registered office and contact details | D-1 Block, Plot No. 18/2, M.I.D.C, Chinchwad, Pune: 411019 T: 020 6614 2078/ 2049 |
| vi) | Whether listed company | Yes |
| vii) | Name, Address and Contact details of Registrar and Transfer Agent, if any | Link Intime India Pvt. Ltd, Block No. 202, Akshay Complex, Near Ganesh Temple, Off. Dhole Patil Road, Pune - 411 001 Phone: +91 20 26160084 26161629 |

II. PRINCIPAL BUSINESS ACTIVITIES OF THE COMPANY:

All the business activities contributing 10 % or more of the total turnover of the Company shall be stated:

| Sr. No. | Name and Description of main products/ services | NIC Code of the Product/service Company | % to total turnover of the |
|---------|---|---|----------------------------|
| | Manufacturing of Auto Components | 3748 | 100 |

III. PARTICULARS OF HOLDING, SUBSIDIARY AND ASSOCIATE COMPANIES:

| Sr. No. | Name and address of the company | CIN/GLN | Holding/ Subsidiary/ Associate | % of shares held | Applicable Section |
|---------|---------------------------------|---------|--------------------------------|------------------|--------------------|
| NIL | | | | | |

IV. SHARE HOLDING PATTERN (Equity Share Capital Breakup as percentage of Total Equity)

Category-wise Share Holding

| Category of Shareholders | No. of Shares held at the beginning of the year [As on 1 st April, 2019] | | | | No. of Shares held at the end of the year [As on 31 st March, 2020] | | | | % Change during the year |
|---|--|----------------|----------------|--------------|---|----------------|----------------|-------------------|--------------------------|
| | Demat | Physical | Total | % of Total | Demat Shares | Physical | Total | % of Total Shares | |
| A. Promoter s | - | - | - | - | - | - | - | - | - |
| (1) Indian | - | - | - | - | - | - | - | - | - |
| a) Individual/ HUF | 4471429 | 274694 | 4746123 | 26.80 | 4471429 | 274694 | 4746123 | 26.80 | 0.00 |
| b) Central Govt | - | - | - | - | - | - | - | - | - |
| c) State Govt(s) | - | - | - | - | - | - | - | - | - |
| d) Bodies Corp. | 3026105 | 927578 | 3953683 | 22.33 | 3026105 | 927578 | 3953683 | 22.33 | 0.00 |
| e) Banks / FI | - | - | - | - | - | - | - | - | - |
| f) Any other | - | - | - | - | - | - | - | - | - |
| Sub Total (A) (1) | 7497534 | 1202272 | 8699806 | 49.13 | 7497534 | 1202272 | 8699806 | 49.13 | 0.00 |
| (2) Foreign | - | - | - | - | - | - | - | - | - |
| a) NRI Individuals | - | - | - | - | - | - | - | - | - |
| b) Other Individuals | - | - | - | - | - | - | - | - | - |
| c) Bodies Corp. | - | - | - | - | - | - | - | - | - |
| d) Any other | - | - | - | - | - | - | - | - | - |
| Sub Total (A) (2) | - | - | - | - | - | - | - | - | - |
| TOTAL (A) | 7497534 | 1202272 | 8699806 | 49.13 | 7497534 | 1202272 | 8699806 | 49.13 | 0.00 |
| B. Public Shareholding | | | | | | | | | |
| 1. Institutions | | | | | | | | | |
| a) Mutual Funds | 12 | 682 | 694 | 0.00 | 12 | 682 | 694 | 0.00 | 0.00 |
| b) Venture Capital Funds | - | - | - | - | - | - | - | - | - |
| c) Alternate Investment Funds | - | - | - | - | - | - | - | - | - |
| d) Foreign Venture Capital Investors | - | - | - | - | - | - | - | - | - |
| e) Foreign Portfolio Investor | 64 | 192 | 256 | 0.00 | 64 | 192 | 256 | 0.00 | 0.00 |
| f) Financial Institutions/Banks | 69714 | 2465 | 72179 | 0.40 | 69774 | 2465 | 72239 | 0.40 | 0.00 |
| g) Insurance Companies | - | - | - | - | - | - | - | - | - |
| h) Provident fund/ Pension fund | - | - | - | - | - | - | - | - | - |
| Sub-Total (B)(1):- | 69790 | 3339 | 73129 | 0.41 | 69850 | 3339 | 73189 | 0.41 | 0.00 |
| 2. Central Govt./State Govt./ President of India | - | - | - | - | - | - | - | - | - |
| Sub-Total (B)(2) | - | - | - | - | - | - | - | - | - |
| 3. Non-Institutions | | | | | | | | | |
| a) Individuals | | | | | | | | | |
| i) Individual shareholders holding nominal share capital upto INR 2 Lakhs. | 3053551 | 434857 | 3488408 | 19.70 | 2999335 | 421757 | 3421092 | 19.32 | (0.38) |
| ii) Individual shareholders holding nominal share capital in excess of INR 2 Lakhs. | 1095805 | 845309 | 1941114 | 10.96 | 1407553 | 620710 | 2028263 | 11.45 | 0.49 |
| b) NBFCs registered with RBI | 289 | 0 | 289 | <0.001 | 0 | 0 | 0 | 0.00 | (<0.001) |
| c) Employee Trusts | - | - | - | - | - | - | - | - | - |
| d) Overseas Depositories (holding DRs) | - | - | - | - | - | - | - | - | - |
| e) Any Others (specify) | - | - | - | - | - | - | - | - | - |
| Trusts | 44 | 18 | 62 | <0.001 | 44 | 18 | 62 | <0.001 | 0.00 |
| Hindu Undivided Family | 319553 | 0 | 319553 | 1.80 | 339802 | 0 | 339802 | 1.92 | 0.12 |
| Foreign Companies | 519586 | 0 | 519586 | 2.93 | 519586 | 0 | 519586 | 2.93 | 0.00 |

IV. SHARE HOLDING PATTERN (Equity Share Capital Breakup as percentage of Total Equity)

Category-wise Share Holding

| Category of Shareholders | No. of Shares held at the beginning of the year [As on 1 st April, 2019] | | | | No. of Shares held at the end of the year [As on 31 st March, 2020] | | | | % Change during the year |
|--|--|----------------|-----------------|--------------|---|----------------|-----------------|-------------------|--------------------------|
| | Demat | Physical | Total | % of Total | Demat Shares | Physical | Total | % of Total Shares | |
| Non Resident Indians (Non Repatriation & Repatriation) | 68167 | 24472 | 92639 | 0.52 | 64595 | 24216 | 88811 | 0.50 | (0.02) |
| Overseas Bodies Corporate | 0 | 342 | 342 | <0.002 | 0 | 342 | 342 | <0.002 | 0.00 |
| Clearing Members | 19750 | 0 | 19750 | 0.11 | 3606 | 0 | 3606 | 0.02 | (0.09) |
| Bodies corporate | 2546046 | 7897 | 2553943 | 14.42 | 2532118 | 1944 | 2534062 | 14.31 | (0.11) |
| Sub-total (B)(3):- | 7622791 | 1312895 | 8935686 | 50.46 | 7866639 | 1068987 | 8935626 | 50.46 | 0.00 |
| Total Public (B)= (B1+B2+B3) | 7692581 | 1316234 | 9008815 | 50.87 | 7936489 | 1072326 | 9008815 | 50.87 | 0.00 |
| C. Shares held by Custodian for GDRs & ADRs | - | - | - | - | - | - | - | - | - |
| Grand Total (A+B+C) | 15190115 | 2518506 | 17708621 | 100 | 15434023 | 2274598 | 17708621 | 100 | 0.00 |

ii) Shareholding of Promoter-

| Sl. No. | Shareholder's Name | Shareholding at the beginning of the year | | | Shareholding at the end of the year | | | % Change in share holding during the year |
|---------|--------------------------------------|---|----------------------------------|--|-------------------------------------|----------------------------------|--|---|
| | | No. of Shares | % of total Shares of the company | % of Shares Pledged / encumbered to total shares | No. of Shares | % of total Shares of the company | % of Shares Pledged / encumbered to total shares | |
| 1 | Mr. Arun H. Firodia | 141230 | 0.80 | - | 141230 | 0.80 | - | 0.00 |
| 2 | Dr. Jayashree A. Firodia | 3475222 | 19.62 | - | 3475222 | 19.62 | - | 0.00 |
| 3 | Ms. Sulajja F. Motwani | 616 | <0.003 | - | 616 | <0.003 | - | 0.00 |
| 4 | Mr. Ajinkya A. Firodia | 1129055 | 6.38 | - | 1129055 | 6.38 | - | 0.00 |
| 5 | M/s. Micro Age Instruments Pvt. Ltd. | 3953683 | 22.33 | - | 3953683 | 22.33 | - | 0.00 |

iii) Change in Promoters' Shareholding - No Change

| Sr. No. | Name of Shareholder, Date and Reason of Change | Shareholding at the beginning of the year As on 01 st April, 2019 | | Shareholding at the end of the year As on 31 st March, 2020 | |
|---------|--|---|----------------------------------|---|----------------------------------|
| | | No. of Shares | % of total shares of the company | No. of Shares | % of total shares of the company |
| 1. | Mr. Arun H. Firodia | 141230 | 0.80 | 141230 | 0.80 |
| 2. | Dr. Jayashree Firodia | 3475222 | 19.62 | 3475222 | 19.62 |
| 3. | Ms. Sulajja Firodia Motwani | 616 | <0.003 | 616 | <0.003 |
| 4. | Mr. Ajinkya A. Firodia | 1129055 | 6.38 | 1129055 | 6.38 |
| 5. | M/s. Micro Age Instruments Private Limited | 3953683 | 22.33 | 3953683 | 22.33 |

(iv) SHAREHOLDING PATTERN OF TOP TEN SHAREHOLDERS (OTHER THAN DIRECTORS, PROMOTERS AND HOLDERS OF GDRS AND ADRS):

| Sl. No. | Name of the Shareholder | Shareholding at the beginning of the year As on 1 st April, 2019 | | Change during the year (No. of Shares) | | Cumulative Shareholding at the end of the year 31 st March, 2020 | |
|---------|--|--|-------------|---|---------------|---|-------------|
| | | No. of shares held | % of shares | No. of shares | No. of shares | No. of shares held | % of shares |
| 1. | Ashoka Investment Holdings Limited Sale / Purchase At the end of the year | 1750452 | 9.88 | Nil | Nil | 1750452 | 9.88 |
| 2. | Reliance Corporate Advisory Services Ltd. Sale / Purchase At the end of the year | 599700 | 3.38 | Nil | Nil | 599700 | 3.38 |
| 3. | Harsha Hitesh Javeri Sale / Purchase At the end of the year | 405000 | 2.29 | Nil | Nil | 405000 | 2.29 |
| 4. | AIA Singapore Private Ltd. Sale / Purchase At the end of the year | 317910 | 1.80 | Nil | Nil | 317910 | 1.80 |
| 5. | AIA International Limited Sale / Purchase At the end of the year | 201676 | 1.14 | Nil | Nil | 201676 | 1.14 |
| 6. | Hitesh Ramji Javeri Sale /Purchase At the end of the year | 150013 | 0.85 | Nil | Nil | 150013 | 0.85 |
| 7. | Bharat Jamnadas Dattani Purchase At the end of the year | 76545 | 0.43 | 4638 | 0.03 | 81183 | 0.46 |

(iv) SHAREHOLDING PATTERN OF TOP TEN SHAREHOLDERS (OTHER THAN DIRECTORS, PROMOTERS AND HOLDERS OF GDRS AND ADRS):

| Sl. No. | Name of the Shareholder | Shareholding at the beginning of the year As on 1st April, 2019 | | Change during the year (No. of Shares) | | Cumulative Shareholding at the end of the year 31 st March, 2020 | |
|---------|---|--|-------------|---|---------------|---|-------------|
| | | No. of shares held | % of shares | No. of shares | No. of shares | No. of shares held | % of shares |
| 8. | Life Insurance Corporation of India Sale / Purchase At the end of the year | 69604 | 0.39 | Nil | Nil | 69604 | 0.39 |
| 9. | Bharati Bharat Dattani Purchase At the end of the year | 67272 | 0.38 | 1000 | 0.00 | 68272 | 0.39 |
| 10. | Jay Bharat Dattani Sale / Purchase At the end of the year | 48927 | 0.28 | Nil | Nil | 48927 | 0.28 |

iV) Shareholding of Directors:

| Sl. No. | Shareholder's Name | Shareholding at the beginning of the year | | | Shareholding at the end of the year | | | % Change in share holding during the year |
|---------|--------------------------|---|----------------------------------|--|-------------------------------------|----------------------------------|--|---|
| | | No. of Shares | % of total Shares of the company | % of Shares Pledged / encumbered to total shares | No. of Shares | % of total Shares of the company | % of Shares Pledged / encumbered to total shares | |
| 1. | Mr. Arun H. Firodia | 141230 | 0.80 | - | 141230 | 0.80 | - | 0.00 |
| 2. | Dr. Jayashree A. Firodia | 3475222 | 19.62 | - | 3475222 | 19.62 | - | 0.00 |
| 3. | Ms. Sulajja F. Motwani | 616 | <0.003 | - | 616 | <0.003 | - | 0.00 |
| 4. | Mr. Ajinkya A. Firodia | 1129055 | 6.38 | - | 1129055 | 6.38 | - | 0.00 |
| 5. | Mr. Shirish R. Kotecha | 0 | 0.00 | - | 0 | 0.00 | - | 0.00 |
| 6. | Mr. Ramesh J. Kabra | 525 | <0.003 | - | 525 | <0.003 | - | 0.00 |
| 7. | Mr. Rohit P. Bafana | 10302 | 0.06 | - | 10302 | 0.06 | - | 0.00 |
| 8. | Mr. Rajiv I. Ranka* | - | - | - | - | - | - | - |

* Appointed as Independent directors on 17th July, 2019.

Vi) SHAREHOLDING OF KEY MANAGERIAL PERSONNEL:

| Sl. No. | Shareholder's Name | Shareholding at the beginning of the year As on 1st April, 2019 | | | Shareholding at the end of the year 31 st March, 2020 | | | % Change in share holding during the year |
|---------|------------------------|--|----------------------------------|--|---|----------------------------------|--|---|
| | | No. of Shares | % of total Shares of the company | % of Shares Pledged / encumbered to total shares | No. of Shares | % of total Shares of the company | % of Shares Pledged / encumbered to total shares | |
| 1. | Mr. Ajinkya A. Firodia | 1129055 | 6.38 | - | 1129055 | 6.38 | - | 0.00 |
| 2. | Mr. Chaitanya Koranne | 5 | <0.0001 | - | 5 | <0.0001 | - | 0.00 |
| 3. | Ms. Deepal Shah* | 0 | <0.0001 | - | 1 | <0.0001 | - | 0.00 |
| 4. | Mr. Nikhil Deshpande** | 0 | 0.00 | - | 0 | 0.00 | - | 0.00 |

* Ceased from the employment of the Company effective from 03rd June, 2019.

** Appointed as Company Secretary effective from 15th November, 2019.

V. INDEBTNESS
INDEBTEDNESS OF THE COMPANY INCLUDING INTEREST OUTSTANDING/ACCRUED BUT NOT DUE FOR PAYMENT:

| Particulars | Secured Loans excluding deposits (INR) | Unsecured Loans (INR) | Deposits (INR) | Total Indebtedness (INR) |
|--|--|-----------------------|----------------|--------------------------|
| Indebtedness at the beginning of the financial year | | | | |
| i) Principal Amount | 193,866,062 | 557,204,931 | - | 751,070,994 |
| ii) Interest due but not paid | - | 12,408,604 | - | 12,408,604 |
| iii) Interest accrued but not due | - | 1,795,417 | - | 1,795,417 |
| Total (i+ii+iii) | 193,866,062 | 571,408,952 | - | 765,275,015 |
| Change in Indebtedness during the financial year | | | | |
| i) Addition | - | - | - | - |
| ii) Reduction | 7,723,469 | 1,963,815 | - | 9,687,284 |
| Net Change | 7,723,469 | 1,963,815 | - | 9,687,284 |
| Indebtedness at the end of the financial year | | | | |
| i) Principal Amount | 186,142,593 | 555,299,048 | - | 741,441,641 |
| ii) Interest due but not paid | - | 12,408,604 | - | 12,408,604 |
| iii) Interest accrued but not due | - | 1,737,485 | - | 1,737,485 |
| Total (i+ii+iii) | 186,142,593 | 569,445,137 | - | 755,587,730 |

VI. REMUNERATION OF DIRECTORS AND KEY MANAGERIAL PERSONNEL:
A. REMUNERATION TO MANAGING DIRECTOR, WHOLE TIME DIRECTOR AND/OR MANAGER:

| Particulars of Remuneration | Name of MD/WTD/Manager | Total |
|--|---|------------------|
| | Mr. Ajinkya A. Firodia (Managing Director) | |
| Gross Salary: | | |
| (a) Salary as per provisions contained in Section 17(1) of the Income Tax Act, 1961. | 5,195,898 | 5,195,898 |
| (b) Value of perquisites under section 17(2) of Income Tax Act, 1961 | 15,000 | 15,000 |
| (c) Profits in lieu of salary under Section 17(3) of Income Tax Act, 1961 | - | - |
| Stock Option: | - | - |
| Sweat Equity: | - | - |
| Commission:- as % of profit- others, specify | - | - |
| Total | 52,10,898 | 52,10,898 |

B. REMUNERATION TO OTHER DIRECTORS:
(I). INDEPENDENT DIRECTORS:

(Amount in INR)

| Particulars of Remuneration | Name of the Independent Director | | | | Total Amount |
|---|----------------------------------|---------------------|---------------------|---------------------|---------------|
| | Mr. Shirish R. Kotecha | Mr. Ramesh J. Kabra | Mr. Rohit P. Bafana | Mr. Rajiv I. Ranka* | |
| Fee for attending Board/ Committee Meetings | 13,500 | 16,000 | 20,500 | 9,000 | 59,000 |
| Commission | - | - | - | - | - |
| Others, please Specify | - | - | - | - | - |
| Total (I) | 13,500 | 16,000 | 20,500 | 9,000 | 59,000 |

 *Appointment of Mr. Rajiv I. Ranka made w.e.f. 17th July, 2019.

(II) OTHER NON-EXECUTIVE DIRECTORS:

(Amount in INR)

| Particulars of Remuneration | Name of the Directors Dr. Jayashree A. Firodia | Total Amount |
|--|---|---------------|
| Fee for attending Board/Committee Meetings | 12,500 | 12,500 |
| Commission | - | - |
| Others, please Specify | - | - |
| Total (II) | 12,500 | 12,500 |
| Total (B)=[I+II] | | 71,500 |

C. REMUNERATION OTHER THAN MD/ WTD/ MANAGER:

(Amount in INR)

| Sr. No | Particulars of Remuneration | Company Secretary | | | Total |
|-----------------------------------|---|-------------------------|------------------|------------------------|------------------|
| | | Cheif Executive Officer | | | |
| | | Mr. Chaitanya Koranne | Ms. Deepal* Shah | Mr. Nikhil** Deshpande | |
| 1. Gross Salary: | | | | | |
| (a) | Salary as per provisions contained in section 17(1) of the Income Tax Act, 1961 | 41,90,184 | 1,64,698 | 7,08,975 | 50,63,857 |
| (b) | Value of perquisites under section 17(2) Income Tax Act, 1961 | 4,95,000 | 28,544 | 7,792 | 5,31,336 |
| (c) | Profits in lieu of salary under section 17(3) Income Tax Act, 1961 | - | - | - | - |
| 2. Stock Option: | | - | - | - | - |
| 3. Sweat Equity: | | - | - | - | - |
| 4. Commission:- | as % of profit- others, specify | - | - | - | - |
| 5. Others, Please Specify: | | - | - | - | - |
| | Total (C) | 46,85,184 | 1,93,242 | 7,16,767 | 55,95,193 |

* Ceased from the employment of the Company effective from 03rd June, 2019.

** Appointed as Company Secretary effective from 15th November, 2019.

VII. PENALTIES/ PUNISHMENT/ COMPOUNDING OF OFFENCES:

| Type | Section of the Companies Act | Brief Description | Details of Penalty / Punishment/ Compounding fees imposed | Authority [RD / NCLT / COURT] Details) | Appeal made, if any (give |
|---|------------------------------|-------------------|---|--|---------------------------|
| A. COMPANY Penalty Punishment Compounding | NIL | | | | |
| B. DIRECTORS Penalty Punishment Compounding | | | | | |
| C. OTHER OFFICERS IN DEFAULT Penalty Punishment Compounding | | | | | |

**ANNEXURE-III
POLICIES AT THE GLANCE****A. Preservation & Archival Policy:**

Pursuant to Regulation 9 of Listing Regulations, 2015, the Board of Directors has adopted Policy on Preservation of Documents. This Policy envisages the procedure governing preservation of documents as required to be maintained under the various statutes. The Policy can be accessed from the Company's website at www.kineticindia.com/investors.

Pursuant to Regulation 30(8) of Listing Regulations, 2015, every listed company shall disclose on its website, all such events or information which have been disclosed to the stock exchange(s) under Regulation 30. Such disclosures shall be posted on the website of the company for a minimum period of five years and thereafter as per the archival policy of the company. Accordingly, the Board of Directors has approved the 'Archival Policy'. The Policy can be accessed from the Company's website at www.kineticindia.com/investors.

B. Policy on Determination of Materiality for Disclosures of Events or Information:

Pursuant to Regulation 30 of Listing Regulation 2015, the Board of Directors has adopted the Policy for Determination of Material Events or information. The objective of the Policy is to ensure timely and adequate disclosure of material events or information. The Policy can be accessed from the company's website at www.kineticindia.com/investors.

C. Remuneration Policy:

The Company had framed a remuneration policy to review the existing tenure of all its directors and criteria for the appointment/re-appointment of directors wherein it takes into account, various factors viz. remuneration package offered to Senior Directors in the automobile and engineering industry, trends in industry, financial position of the Company, performance of the Executive Directors, their qualifications, experience and past remuneration, terms of employment, etc. The components of remuneration include Basic Salary, Allowances, Perquisites and Retirement Benefits. The Policy can be accessed from the company's website at www.kineticindia.com/investors.

D. Whistle Blower Policy:

Your Company has established a Vigil Mechanism/ Whistle Blower Policy to enable stakeholders (including Directors and employees) to report unethical behaviour, actual or suspected fraud or violation of the Company's Code of Conduct. The Policy provides adequate safeguards against victimization of Director(s)/ employee(s) and direct access to the Chairman of the Audit Committee in exceptional cases. The Protected Disclosures, if any reported under this Policy will be appropriately and expeditiously investigated by the Chairman.

Your Company hereby affirms that no Director/ employee have been denied access to the Chairman of the Audit Committee and that no complaints were received during the year. The Policy can be accessed from the company's website at www.kineticindia.com/investors.

ANNEXURE-IV

Form No. MR 3

Secretarial Audit Report

(For the year ended 31st March, 2020)

[Pursuant to Section 204(1) of the Companies Act, 2013 and Rule No. 9 of the Companies
(Appointment and Remuneration of Managerial Personnel) Rules, 2014]

To,
The Board of Directors
Kinetic Engineering Limited
D 1 Block, Plot No. 18/2
Chinchwad, Pune 411019.

I have conducted the secretarial audit of the compliance of applicable statutory provisions and the adherence to good corporate practices by **Kinetic Engineering Limited** (hereinafter called the Company). Secretarial Audit was conducted in a manner that provided us a reasonable basis for evaluating the corporate conducts/statutory compliances and expressing my opinion thereon.

Based on my verification of the books, papers, minute books, forms and returns filed and other records maintained by the Company and also the information provided by the Company, its officers, agents and authorized representatives during the conduct of secretarial audit, I hereby report that in my opinion, the Company has, during the audit period ended on 31st March, 2020 complied with the statutory provisions listed hereunder and also that the Company has proper Board-processes and compliance-mechanism in place to the extent, in the manner and subject to the reporting made hereinafter:

I have examined the books, papers, minute books, forms and returns filed and other records maintained by **Kinetic Engineering Limited ("The Company")** for the financial year ended on 31st March, 2020 according to the provisions of:

- i. The Companies Act, 2013 (**the Act**) and the Rules made thereunder;
- ii. The Securities Contracts (Regulation) Act, 1956 (**'SCRA'**) and the Rules made thereunder;
- iii. The Depositories Act, 1996 and the Regulations and Bye-laws framed thereunder as amended by Securities and Exchange Board of India (Depositories and Participants) Regulations, 2018;
- iv. Foreign Exchange Management Act, 1999 and the Rules and Regulations made thereunder to the extent of Foreign Direct Investment, Overseas Direct Investment and External Commercial Borrowings;
- v. The following Regulations and Guidelines prescribed under the Securities and Exchange Board of India Act, 1992 (**'SEBI Act'**) to the extent applicable to the Company:-

- a. The Securities and Exchange Board of India (Substantial Acquisition of Shares and Takeovers) Regulations, 2011;
- b. The Securities and Exchange Board of India (Prohibition of Insider Trading) Regulations, 2015;
- c. The Securities and Exchange Board of India (Issue of Capital and Disclosure Requirements) Regulations, 2009 as amended by The Securities and Exchange Board of India (Issue of Capital and Disclosure Requirements) Regulations, 2018;
- d. The Securities and Exchange Board of India (Registrars to an Issue and Share Transfer Agents) Regulations, 1993 regarding the Companies Act and dealing with client;
Not applicable as the Company is not registered as Registrar to Issue and Share Transfer Agent during the financial year under review
- e. The Securities and Exchange Board of India (Share Based Employee Benefits) Regulations, 2014
Not Applicable as the Company has not issued or listed any such securities during the financial year under review.
- f. The Securities and Exchange Board of India (Issue and Listing of Debt Securities) Regulations, 2008; and
Not Applicable as the Company has not issued and listed any debt securities during the financial year under review
- g. The Securities and Exchange Board of India (Delisting of Equity Shares) Regulations, 2009; and
Not Applicable as the Company has not delisted/propose to delist its equity shares from any Stock Exchange during the financial year under review
- h. The Securities and Exchange Board of India (Buyback of Securities) Regulations, 1998;

Not Applicable as the Company has not bought back/proposed to buyback any of its securities during the financial year under review

- i. the Company has complied with the requirements under the Equity Listing Agreements entered into with BSE Limited; and
 - j. The Memorandum and Articles of Association.
- Since the Company is engaged in manufacture of Auto components and accessories thereof. There are no specific laws applicable to such sector.

I have also examined compliance with the applicable clauses of the following:

- i. Secretarial Standards issued by The Institute of Company Secretaries of India.
- ii. The Listing Agreements entered into by the Company with the BSE Limited

During the period under review the Company has complied with the provisions of the Act, Rules, Regulations, Guidelines, Standards, Listing Agreements etc mentioned above subject to following observations:

| Intimation(s) | Regulation(s) | Filing Due date | Actual filing detail(s) |
|--|---|-------------------------------|-------------------------|
| Two Independent Directors ceased their directorship on 31st March, 2019 due to end of their tenure of 5 years. | Regulation 30 of the SEBI (LODR), Regulations, 2015 | Upon occurrence of such event | 15th April, 2019. |

I further report that:

The Board of Directors of the Company is duly constituted with proper balance of Executive Directors, Non-Executive Directors and Independent Directors. The changes in the composition of the Board of Directors that took place during the period under review were carried out in compliance with the provisions of the Act.

Adequate notice is given to all directors to schedule the Board Meetings, agenda and detailed notes on agenda were sent at least seven days in advance, and a system exists for seeking and obtaining further information and clarifications on the agenda items before the meeting and for meaningful participation at the meeting.

Majority decision is carried through while the dissenting members' views, if any, are captured and recorded as part of the minutes.

I further report that there are adequate systems and processes in the company commensurate with the size and operations of the Company to monitor and ensure compliance with applicable laws, rules, regulations and guidelines.

I further report that during the audit period no major decisions, specific actions/ events have occurred which has major bearing on the Company's affairs in pursuance of the above referred laws, rules, regulations, guidelines, standards etc.

For Dinesh Birla & Associates
Company Secretaries

Dinesh Birla
Proprietor
FCS: 7658, CP No. : 13029
UDIN:F007658B000994644

Place: Pune
Date: 20th October, 2020

Note: This report is to be read with our letter of even date, which is annexed as Annexure A and forms an integral part of this report.

Annexure - A

To,

The Board of Directors
Kinetic Engineering Limited
D 1 Block, Plot No. 18/2
Chinchwad, Pune 411019.

I further report that:

1. Maintenance of secretarial records is the responsibility of the management of the Company. My responsibility is to express an opinion on these secretarial records based on our audit.
2. I have followed the audit practices and processes, as were appropriate to obtain reasonable assurance about the correctness of the contents of the secretarial records. The verification was done on test basis to ensure that correct facts are reflected in secretarial records. I believe that the processes and practices, I followed, provide a reasonable basis for my opinion.
3. Wherever required, I have obtained Management representation(s) about the compliance of Laws, Rules, regulations and happening of events etc.
4. The compliance of the provisions of corporate and other applicable Laws, Rules, Regulations, and Standards is the responsibility of the Management. My examination was limited to the verification of procedures on test basis.
5. We have also relied on the documents and evidences provided on email to us, in view of the prevailing pandemic situation of COVID -19.
6. The Secretarial Audit report is neither an assurance as to the future viability of the Company nor the efficacy or effectiveness with which the Management has conducted the affairs of the Company.

For Dinesh Birla & Associates
Company Secretaries

Dinesh Birla
Proprietor
FCS: 7658, CP No. : 13029
UDIN:F007658B000994644

Place: Pune
Date: 20th October, 2020

Note: This report is to be read with our letter of even date, which is annexed as Annexure A and forms an integral part of this report.

ANNEXURE - V
Information pursuant to Section 197(12) of Companies Act, 2013 read with Rule 5 of The Companies (Appointment and Remuneration of Managerial Personnel) Rules, 2014

1. The ratio of the remuneration of each Director and Key Managerial Personnel (KMP) to the median remuneration of the employees of the Company for the financial year ended 31st March, 2020

| Name | Designation | Ratio of remuneration to the median remuneration | % increase in the remuneration in the financial year |
|-----------------------------|---------------------------------|---|---|
| Mr. Arun H Firodia | Chairman Non-Executive Director | NA* | NA* |
| Dr. Jayashree A Firodia | Non-Executive Director | NA* | NA* |
| Ms. Sulajja Firodia Motwani | Executive Director | NA* | NA* |
| Mr. Ajinkya Firodia | Managing Director | 39 | -10.76 |
| Mr. Shirish Kotecha | Independent Director | NA* | NA* |
| Mr. Ramesh Kabra | Independent Director | NA* | NA* |
| Mr. Rohit Bafana | Independent Director | NA* | NA* |
| Mr. Rajiv Ranka | Independent Director | NA* | NA* |
| Mr. Chaitanya Koranne | Chief Executive Officer | 35 | -9.07 |
| Mr. Nikhil Deshpande | Company Secretary | NA# | NA# |
| Ms. Deepal Shah | Company Secretary | NA# | NA# |

* Do not draw any remuneration from the Company.

Ratio of Remuneration to the median remuneration and % increase in the remuneration in the financial year cannot be calculated since employed for part of the year.

2. The median remuneration of the employees of the Company during the financial year ended 31st March, 2020 was INR 1,34,203
3. The percentage increase in the median remuneration of employees in the financial year was - 3%
4. The number of permanent employees on the rolls of the Company: 720
5. Average percentile increase already made in the salaries of the employees other than the managerial personnel in the last financial year and its comparison with the percentile increase in the managerial remuneration and justification thereof and point out if there are any exceptional circumstances for increase in the managerial remuneration: N.A
6. We confirm that the remuneration is as per the remuneration policy recommended by the Nomination and Remuneration Committee of the Company and adopted by the Company.

**REPORT ON CORPORATE GOVERNANCE
FOR THE YEAR ENDED 31ST MARCH, 2020.**

1. Corporate Governance Philosophy:

The Corporate Governance standards demonstrate inalienable rights vested with various stakeholders, and strong commitment to values, ethics and business conduct. The Company is committed to good corporate governance, based on an effective Independent Board, separation of supervisory role from the executive management and the constitution of committees to oversee critical areas thus upholding the standards practically at every sphere ranging from action plans to performance measurement and consumer satisfaction.

Kinetic Engineering Limited Corporate Governance philosophy is about intellectual honesty, whereby the governance is not just about encompassing regulatory and legal requirements but also strives to enhance stakeholders' value as a whole. The Company's philosophy includes protection and facilitation of shareholders' rights, provide adequate and timely information and ensuring equitable treatment to all shareholders. The Company also ensures timely and accurate disclosure on all material matters including the financial situation, performance, ownership and governance of the Company.

2. Board of Directors:

2.1 We believe that our Board needs to have an appropriate mix of Executive, Non-Executive and Independent Directors to maintain its independence, and separate its functions of governance and management. The SEBI (Listing Obligations and Disclosure Requirements)

Regulations, 2015 (hereby referred to as "Listing Regulations, 2015") mandate that for a Company with a Non-Executive Chairman, who is a promoter, at least fifty percent of the Board should comprise of Independent Directors.

As on 31st March, 2020, our Board comprised eight members, consisting of a Non- Executive Chairman, two Executive Directors and five Non-Executive Directors where in four are Independent Directors. Two out of eight members are Women Directors. The composition of Board is in accordance with the requirements of Listing Regulations, 2015 & Companies Act, 2013.

All the directors possess the requisite qualifications and experience in corporate management and finance, banking and other allied fields enabling them to contribute effectively in their capacity as Directors of the Company.

All the Independent Directors of the Company furnish declaration annually that they qualify the conditions of their being independent. All such declarations are placed before the Board. Further all the Directors provide declarations annually that they have not been disqualified to act as Director under Section 164 (2) of the Companies Act, 2013.

A certificate has been received from Dinesh Birla & Associates, Practicing Company Secretaries, that none of the Directors on the Board of the Company has been debarred or disqualified from being appointed or continuing as directors of companies by the Securities and Exchange Board of India, Ministry of Corporate Affairs or any such statutory authority.

2.2 The Composition of the Board as on 31st March, 2020 and category of Directors are as under:

| Name of the Director | Designation | Category | No of other Directorships held # | No. of Independent Directorships held Companies# in Listed | No. of other Board committees ## | |
|-----------------------------|-------------|--------------------------|----------------------------------|--|----------------------------------|--------|
| | | | | | Chairman | Member |
| Mr. Arun H. Firodia | Chairman | Promoter/ Non-Executive | 3 | NIL | - | - |
| Dr. Jayashree A. Firodia | Director | Promoter/ Non- Executive | 4 | NIL | - | - |
| Ms. Sulajja Firodia Motwani | Director | Promoter/ Executive | 2 | NIL | - | - |
| Mr. Ajinkya A. Firodia | Director | Promoter / Executive | 6 | 1 | - | - |
| Mr. Shirish R. Kotecha | Director | Independent | 2 | NIL | - | - |
| Mr Ramesh J. Kabra | Director | Independent | 0 | NIL | - | - |
| Mr.Rohit P. Bafana | Director | Independent | 0 | NIL | - | - |
| Mr. Rajiv I. Ranka* | Director | Independent | 2 | 1 | 1 | 2 |

#Excludes Directorship in Indian Private limited companies, Foreign companies, Companies registered under Section 8 of the Companies Act, 2013 and Directorship in Kinetic Engineering Limited.

Committees considered are Audit Committee and Stakeholders Relationship Committee in Public Companies excluding Kinetic Engineering Limited.

*Mr. Rajiv I. Ranka have been appointed as Non-Executive Independent Directors w.e.f 17th July, 2019.

2.3 None of the Directors of the Company holds membership of more than ten Board Committees or holds Chairmanship of more than five Board Committees. Mr. Ajinkya Arun Firodia, the Non-

Executive Independent Director in ZF Steering Gears (India) Limited ceased to be on the Board effective from 01st April, 2020.

2.4 Attendance of Directors at Board Meetings and at the last Annual General Meeting:

During the 12 months' period ended 31st March, 2020, Five Board Meetings were held on 29th May, 2019, 17th July, 2019, 14th August, 2019, 14th November, 2019, & 13th February, 2020. The maximum time gap between any two Board Meetings was not more than one hundred twenty days.

The details of Attendance of Directors at the Board Meetings and at the last Annual General Meeting are as hereunder:

| Name of the Director | Board meeting held during the tenure of the Director | Board Meeting Attended | Attendance at the last AGM held on 28 th August, 2019 |
|--------------------------|--|------------------------|--|
| Mr. Arun H. Firodia | 5 | 5 | Yes |
| Dr. Jayashree A. Firodia | 5 | 5 | Yes |
| Ms. Sulajja F. Motwani | 5 | 3 | No |
| Mr. Ajinkya A. Firodia | 5 | 5 | Yes |
| Mr. Shirish R. Kotecha | 5 | 3 | Yes |
| Mr. Ramesh J. Kabra | 5 | 4 | No |
| Mr. Rohit P. Bafana | 5 | 5 | Yes |
| Mr. Rajiv I. Ranka | 5 | 2 | Yes |

2.5 Pecuniary relationship or transactions of Non-Executive Directors: Nil

3. Audit Committee:

3.1 Brief description of Terms of Reference:

The primary objective of the audit committee is to monitor and provide an effective supervision of the Management's financial reporting process, to ensure accurate and timely disclosures with the highest levels of transparency, integrity and quality of financial reporting. The Committee oversees the work carried out in the financial reporting process by the Management, the internal auditors and the Independent Auditors and notes the processes and safeguards employed by each of them. The audit committee is responsible to select, evaluate and where appropriate, replace the independent auditors in accordance with the law. All possible measures are taken by the committee to ensure the objectivity and independence of Independent auditors.

3.2 Composition of Committee during the financial year 2019-20:

The Committee is comprised solely of Independent Directors and is in compliance with the requirements of Section 149 of the Companies Act, 2013 & Regulation 18 of the Listing Regulations, 2015 during the financial year 2019-20:

| Name of the Director | Category | Status |
|----------------------|----------------------|----------|
| Mr. Shirish Kotecha | Independent Director | Chairman |
| Mr. Ramesh Kabra | Independent Director | Member |
| Mr. Rohit Bafana | Independent Director | Member |
| Mr. Rajiv Ranka* | Independent Director | Member |

* Mr. Rajiv I. Ranka was inducted as member of the Audit Committee effective from 17th July, 2019.

3.3 Meetings and attendance during the period under review:

During the 12 months period ended on 31st March, 2020, Four Meetings of the Audit Committee were held on 29th May, 2019; 14th August, 2019; 14th November, 2019 and 13th February, 2020. Details of attendance of the Members at the meeting were as follows:

| Name of the Director | No. of Meetings held during the Year | No. of Meetings attended |
|----------------------|--------------------------------------|--------------------------|
| Mr. Shirish Kotecha | 4 | 3 |
| Mr. Ramesh Kabra | 4 | 3 |
| Mr. Rohit Bafana | 4 | 4 |
| Mr. Rajiv Ranka | 4 | 2* |

* Mr. Rajiv I. Ranka was inducted as member of the Audit Committee effective from 17th July, 2019.

The Head of Finance Department, CEO, Internal Auditors, Representative of Statutory Auditors, and other Senior Executives members of the Company were also invited to attend the Audit Committee Meetings. The Company Secretary acts as a secretary to the Audit Committee.

4. Nomination and Remuneration Committee (formerly termed as Remuneration Committee):

4.1 Brief description of Terms of reference:

- ◆ Identifying persons who are qualified to become directors and who may be appointed in senior management in accordance with the criteria laid down and recommend to the Board their appointment and removal.
- ◆ Formulation of criteria for evaluation of Independent Directors and the Board;
- ◆ Formulation of the criteria for determining qualifications, positive attributes and independence of a director and recommend to the Board a policy, relating to the remuneration of the directors, key managerial personnel and other employees;
- ◆ Devising a policy on Board diversity;
- ◆ Recommending to the Board on candidates for any Board vacancies that are to be filled.

4.2 Composition of Committee during the financial year 2019-20:

The composition of the Nomination and Remuneration Committee for the year ended 31st March, 2020 is as follows: -

| Name of the Director | Category | Status |
|----------------------|----------------------|----------|
| Mr. Shirish Kotecha | Independent Director | Chairman |
| Mr. Ramesh Kabra | Independent Director | Member |
| Mr. Rohit Bafana | Independent Director | Member |
| Mr. Rajiv Ranka* | Independent Director | Member |

* Mr. Rajiv I. Ranka was inducted as member of the Nomination and Remuneration Committee effective from 17th July, 2019.

4.3 Meetings and attendance during the period under review:

During the period ended on 31st March, 2020, Two Meetings of the Nomination and Remuneration Committee were held on 17th July, 2019 and 14th November, 2019. Details of attendance of the Members at the meeting were as follows:

| Name of the Director | No. of Meetings held during the Year | No. of Meetings attended |
|----------------------|--------------------------------------|--------------------------|
| Mr. Shirish Kotecha | 2 | 1 |
| Mr. Ramesh Kabra | 2 | 2 |
| Mr. Rohit Bafana | 2 | 2 |
| Mr. Rajiv Ranka | 2 | 1 |

* Mr. Rajiv I. Ranka was inducted as member of the Nomination and Remuneration Committee effective from 17th July, 2019.

The Company Secretary acts as a secretary to the Nomination and Remuneration Committee Meeting.

4.4 Details of Remuneration:

The details of remuneration paid to Executive Directors, as required under Regulation 34 read with Schedule V of the Listing Regulations, 2015 during the financial year ended on 31st March, 2020 are as follows:

| Sr. | Particulars of Remuneration | Name Ajinkya A Firodia | Total |
|-----|---------------------------------------|------------------------|------------------|
| 1 | Gross salary | | |
| | (a.) Salary as per Section 17(1) | 5,195,898 | 5,195,898 |
| | (b.) Perquisites as per section 17(2) | 15,000 | 15,000 |
| 2 | Stock Option | - | - |
| 3 | Sweat Equity | - | - |
| 4 | Commission as % of profit | - | - |
| 5 | Others | - | - |
| | Total (A) | 5,210,898 | 5,210,898 |

All the above remuneration was fixed/ varies with respect to time-scale.

The Non-Executive Directors of the Company are paid sitting fees @ 2500 per Board Meeting and @2000 per Audit Committee Meeting thereof attended by them besides re-imbursement of expenses on traveling etc. No commission is being paid to Non-Executive Directors.

Details of Sitting Fees paid to Non-Executive Directors for attending Board/ Committee Meetings and their shareholding in the Company during the period ended on 31st March, 2020, are as follows:

| Sr. No. | Name of the Non- Executive Director | Sitting Fees(₹) | No. of Shares Held in the Company |
|---------|-------------------------------------|-----------------|-----------------------------------|
| 1 | Dr. Jayashree Firodia | 12,500 | 3,475,222 |
| 2 | Mr. Ramesh Kabra | 16,500 | 525 |
| 3 | Mr. Shirish Kotecha | 13,500 | - |
| 4 | Mr. Rohit Bafana | 20,500 | 10,302 |
| 5 | Mr. Rajiv Ranka* | 9,000 | - |

* Mr. Rajiv I. Ranka was inducted as member of the Nomination and Remuneration Committee effective from 17th July, 2019

5. Stakeholders Relationship Committee (formerly termed as Shareholders' Grievance Committee):

5.1 The Committee assists the Board and the Company in maintaining healthy relationships with all stakeholders. The Committee oversees the mechanisms for redressing grievances and complaints from stakeholders and reviews the matters connected therewith. The Company Secretary acts as a secretary to the Stakeholders Relationship Committee.

5.2 Composition of the Committee during the financial year 2019-20:

The composition of the Stakeholders Relationship Committee for the year ended 31st March, 2020 is as follows:-

| Name of the Director | Category | Status |
|----------------------|----------------------|----------|
| Mr. Shirish Kotecha | Independent Director | Chairman |
| Mr. Ramesh Kabra | Independent Director | Member |
| Mr. Rohit Bafana | Independent Director | Member |
| Mr. Rajiv Ranka* | Independent Director | Member |

*Mr. Rajiv Ranka were appointed as member of the Committee w.e.f. 17th July, 2019.

5.3 Meetings and attendance during the period under review:

During the period ended on 31st March, 2020, three Meetings of the Stakeholders Relationship Committee were held on 29th May, 2019; 14th November, 2019 and 13th February, 2020. Details of attendance of the Members at the meeting were as follows:

| Name of the Director | No. of Meetings held during the Year | No. of Meetings attended |
|----------------------|--------------------------------------|--------------------------|
| Mr. Shirish Kotecha | 3 | 2 |
| Mr. Ramesh Kabra | 3 | 2 |
| Mr. Rohit Bafana | 3 | 3 |
| Mr. Rajiv Ranka | 3 | 2 |

No. of shareholder's complaints/request received during the period under review - 106

No. of complaints/request not resolved to the satisfaction of the shareholders -2

No. of pending Complaints/ request as on 31st March, 2020- 2

As on 31st March, 2020, 2 complaints were outstanding since the Government of India announced nation-wide lockdown during March 2020. However, those unresolved complaints were closed during Q1FY2020-21.

6. Evaluation of Board's performance:

The Nomination and Remuneration Committee of the Board laid down the criteria for performance evaluation of the Board and Individual Directors, including the Chairman of the Board. The exercise was carried out through evaluation process covering various aspects.

The Directors were satisfied with the evaluation results, which reflected the overall engagement of the Board and its Committees.

7. Meeting of Independent Directors:

As stipulated by code for Independent Directors under the Companies Act, 2013 and the Listing Regulations, 2015, a separate meeting of Independent Directors was held on 13th February, 2020 to review the performance of Non-Independent Directors and the Board as a whole on parameters of effectiveness and to

assess the quality, quantity and timeliness of flow of information between the management and the Board.

8. Code of Conduct:

The Board of Directors has laid down Code of Conduct for Board Members and designated Senior Management and Employee of the Company. All Board Members and Senior Management personnel have affirmed compliance with these Codes of Conduct. The code of conduct is available on the website of the Company at www.kineticindia.com/investors. A declaration signed by the Managing Director to this effect is enclosed at the end of this report.

9. Code of Conduct for prohibition of insider trading:

The Company has adopted an Insider Trading policy to regulate, monitor and report trading by insiders under Securities and Exchange Board of India SEBI (Prohibition of Insider

Trading) Regulations, 2015. This policy also includes practices and procedures for fair disclosure of unpublished price-sensitive information, initial and continual disclosures. The policy is available on Company's website of the Company at www.kineticindia.com/investors.

10. Auditors' certificate on Corporate Governance:

As required under Schedule V of the Listing Regulations, 2015 the Auditors' certificate on Corporate Governance is enclosed as Annexure to the Corporate Governance Report.

11. CEO and CFO certification:

As required by the Listing Regulations, 2015, the CEO and CFO certification is provided in this Corporate Governance Report.

12. Compliance Officer:

Mr. Nikhil Deshpande, Company Secretary is the Compliance Officer for complying with the requirements of Companies Act, 2013, SEBI Regulations, Secretarial Standards etc.

13. Annual General Meetings:

The details of the last three Annual General Meetings of the Company are as hereunder:

| Year ended | Date of AGM | Time | Venue | Whether Special Resolution Passed or not | Details of Special Resolution passed |
|------------------------------|----------------------------------|------------|---|--|---|
| 31 st March, 2019 | 28 th August, 2019 | 11.00 a.m. | D-1 Block, Plot No. 18/2, Chinchwad MIDC, Pune – 411019 | YES | Appointment of Mr . Arun H Firodia (DIN 00057324) as Non-Executive Chairman who retired by rotation and being eligible offered himself for reappointment. |
| 31 st March, 2018 | 29 th September, 2018 | 11.00 a.m. | | None | - |
| 31 st March, 2017 | 29 th September, 2017 | 11.00 a.m. | | None | - |

14. Postal Ballot: -

There were no Postal Ballot conducted during the financial year under review.

Remote e-voting and ballot voting at the AGM

To allow the shareholder to vote on the resolutions proposed at the AGM, the Company has arranged for a remote e-voting facility. The company has engaged CDSL to provide e-voting facility to all the members. Members, whose name appears on the register of members as **on Wednesday, the 18th November, 2020** shall be eligible to participate in the e-voting.

15. Disclosures:

(i) **Disclosure on materially significant related party transactions i.e. transactions of the Company of material nature with its promoters, the directors or management, their subsidiaries or relatives etc. that may have potential conflict with interests of Company at large :**

Normal trade transactions were entered into by the Company with the related parties. One Executive Director was paid remuneration. The disclosures on related party transactions as per Accounting Standard 18 notified in the Companies (Accounting Standard) Rules, 2016, are given in Note No. 45 of Notes Forming part of the Financial Statements for the year ended on 31st March, 2020.

- (ii) There were no penalties, nor any restrictions imposed on the Company by SEBI or any Statutory authority, on any matter related to capital markets.
- (iii) The Company has complied with all mandatory requirements of the Listing Regulations, 2015, in respect of Corporate Governance.

16. Means of Communication:

The Company's quarterly/half-yearly/annual financial results are sent to Stock Exchange and published in 'Financial Express' and 'Loksatta' newspapers. Simultaneously, they are also hosted on Company's website - www.kineticindia.com. In terms of SEBI circular, the Company has designated an email address- kelinvestors@kineticindia.com for enabling investors to post their grievances and to enable timely action on investor grievances, if any.

17. Press Releases, News Release:

Official Press Releases are sent to Stock Exchange and are hosted on Company's website. No presentation was made to Institutional Investors or Analysts.

18. General Shareholders Information:

The 49th Annual General Meeting is proposed to be held on **Wednesday, 25th November, 2020** at 11:00 a.m. through Video Conferencing ('VC')/Other Audio Visual Means ('OAVM') facility.

19. Financial Calendar (Tentative):

| Quarter Ending | Date |
|----------------------|----------------------|
| 30th June, 2020 | 14th September, 2020 |
| 30th September, 2020 | 14th November, 2020 |
| 31st December, 2020 | 14th February, 2021 |
| 31st March, 2021 | 29th May, 2021 |

Date of Book Closure: 19th November, 2020 to 25th November, 2020.

a. Dividend Payment Date:

The Directors have not recommended any Dividend for the financial year ended on 31st March, 2020.

b. Listing of Shares on Stock Exchanges:

The shares of the Company are listed on BSE Limited, Phiroze Jeejeebhoy Towers, Dalal Street, Fort Mumbai - 400 001.

c. Payment of Listing Fees:

Annual Listing Fee for the year 2020-21 has been paid by the Company to the stock exchange.

d. Payment of Annual Custodian Fees:

Annual Custodian fees for the year 2020-21 has been paid by the Company to the Central Depository Services (India) Limited (CDSL) and will be paid to National Securities Depository Limited (NSDL) on receipt of invoice.

Stock Code and ISIN:

BSE (Equity Shares) : 500240

ISIN for equity shares : INE266B01017.

Stock Market Price Data (Source: Official Website of BSE www.bseindia.com):

| Month & Year | KEL Share Price | | | BSE Sensex | | |
|-----------------|-----------------|--------------|----------------|------------|----------|----------|
| | High (In INR) | Low (In INR) | Close (In INR) | High | Low | Close |
| April, 2019 | 43.00 | 33.70 | 34.55 | 39487.45 | 38460.25 | 39031.55 |
| May, 2019 | 39.20 | 30.75 | 36.10 | 40124.96 | 36956.10 | 39714.20 |
| June, 2019 | 40.35 | 28.10 | 33.10 | 40312.07 | 38870.96 | 39394.64 |
| July, 2019 | 49.40 | 30.05 | 46.45 | 40032.41 | 37128.26 | 37481.12 |
| August, 2019 | 48.70 | 33.20 | 35.15 | 37807.55 | 36102.35 | 37332.79 |
| September, 2019 | 42.35 | 32.85 | 37.80 | 39441.12 | 35987.80 | 38667.33 |
| October, 2019 | 39.60 | 31.85 | 35.00 | 40392.22 | 37415.83 | 40129.05 |
| November, 2019 | 38.10 | 32.60 | 35.65 | 41163.79 | 40014.23 | 40793.81 |
| December, 2019 | 35.65 | 30.15 | 32.10 | 41809.96 | 40135.37 | 41253.74 |
| January, 2020 | 39.15 | 31.05 | 33.50 | 42273.87 | 40476.55 | 40723.49 |
| February, 2020 | 34.55 | 24.25 | 24.25 | 41709.30 | 38219.97 | 38297.29 |
| March, 2020 | 25.50 | 11.20 | 12.30 | 39083.17 | 25638.90 | 29468.49 |

Performance in comparison to broad based BSE Sensex:

Kinetic Engineering Ltd (KEL) Share price on BSE vis-à-vis BSE Sensex (2019-20)

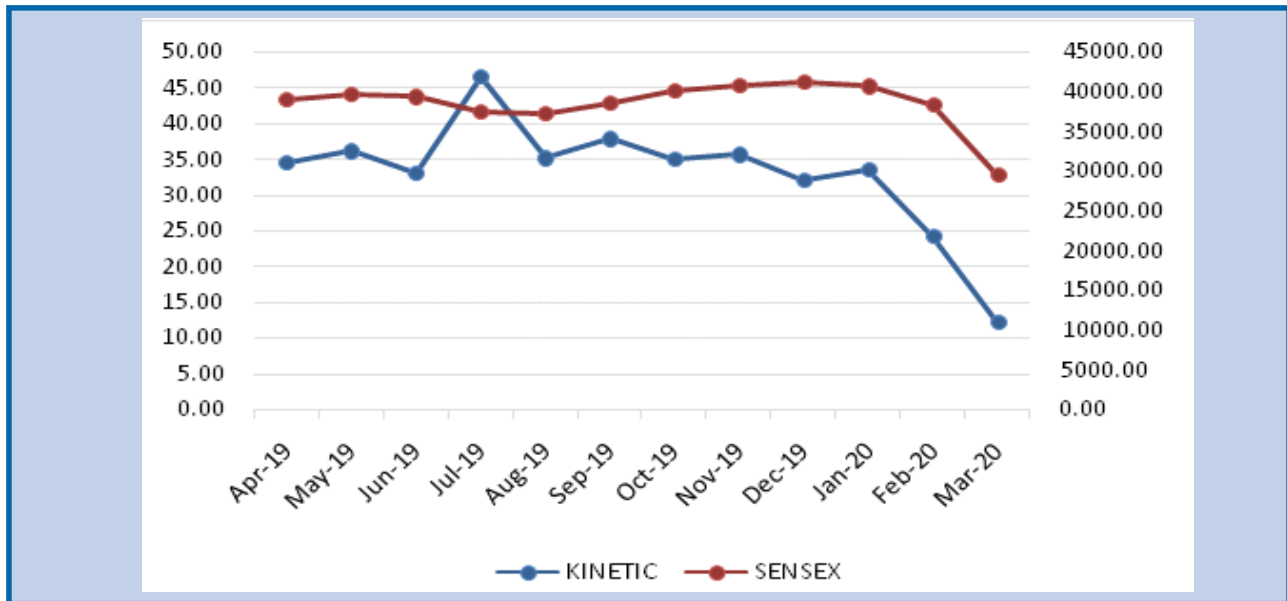

Registrars and Transfer Agents:

The Company’s equity shares are compulsorily traded in Demat mode and hence transferable through the depository system. **Link Intime India Pvt Limited**, Akshay Complex, Block No. 202, 2nd Floor, Dhole Patil Road, Pune-411001 has been appointed as Company’s Registrars and Transfer Agent as per SEBI’s Circular for appointment of Common Agency to carry physical and electronic share registry work.

Share Transfer System:

All the transfers received are processed by the Registrars and Transfer Agent and approved by the Authorised Directors/ Company Secretary of the Company. The demat request which were received in physical form, were processed and the share certificates returned within a period of 30 days from the date of receipt, (as per the relaxation in time line granted for processing of Demat request vide SEBI letter no. NSDL/11/SEBI/PP/2150/2018 dated 24th January, 2019) subject to the documents being valid and complete in all respects.

Distribution of Shareholding as on 31st March, 2020:

| Shareholding of Nominal value (INR) | No. of Shareholders | % of No. of Shareholders | Amount (INR) | % to paid-up Capital |
|-------------------------------------|---------------------|--------------------------|------------------|----------------------|
| Upto 5000 | 19,837 | 94.04 | 12987720 | 7.33 |
| 5001-10000 | 597 | 2.83 | 4764360 | 2.69 |
| 10001-20000 | 288 | 1.36 | 4316120 | 2.44 |
| 20001-30000 | 107 | 0.52 | 2689860 | 1.52 |
| 30001-40000 | 51 | 0.24 | 1836340 | 1.04 |
| 40001-50000 | 48 | 0.23 | 2258400 | 1.27 |
| 50001-100000 | 75 | 0.35 | 5235650 | 2.96 |
| 100001 and above | 91 | 0.43 | 142997760 | 80.75 |
| Total | 21,094 | 100.00 | 177086210 | 100.00 |

Shareholding Pattern as on 31st March, 2020:

| Sr. No. | Category | No. of Shares | Percentage (%) |
|--------------|--|-----------------|----------------|
| A) | Promoter and Promoter Group | | |
| | Indian | 8699806 | 49.13 |
| | Foreign | 0 | 0 |
| | TOTAL (A) | 8699806 | 49.13 |
| B)(I) | Public Shareholding Institutions: | | |
| | Mutual Funds/UTI | 694 | <0.004 |
| | Financial Institutions/Banks | 72239 | 0.41 |
| | Insurance Companies | 0 | 0 |
| | Foreign Portfolio Investors | 256 | 0 |
| | Total B (I) | 73189 | 0.41 |
| (II) | Non- Institutions: | | |
| | Bodies Corporate | 2534062 | 14.31 |
| | Individuals | 5449355 | 30.77 |
| | Clearing Members | 3606 | 0.02 |
| | NRI/ NRN | 88811 | 0.50 |
| | Foreign Companies | 519586 | 2.93 |
| | OCB | 342 | 0.00 |
| | Trusts | 62 | <0.001 |
| | HUF | 339802 | 1.92 |
| | NBFC | 0 | 0 |
| | Total B (II) | 8935626 | 50.46 |
| | TOTAL (B) [I+II] | 9008815 | 50.87 |
| | GRAND TOTAL(A+B) | 17708621 | 100 |

Dematerialization of Shares:

The Company's Shares are compulsory traded on BSE in dematerialized form. As on 31st March, 2020, the details of the Shares of the Company held in physical and demat form are given below:

| Sr. No. | Particulars | No. of Shares | % to the Capital |
|---------|----------------------------------|--------------------|------------------|
| 1. | Shares held in Physical Form | 20,33,579 | 11.48% |
| 2. | Shares held in Demat Form - NSDL | 1,34,00,444 | 75.67% |
| 3. | Shares held in Demat Form - CDSL | 22,74,598 | 12.84% |
| | TOTAL | 1,77,08,621 | 100.00 |

Outstanding GDRs/ADRs/Warrants:Not applicable as not issued.

Plant Locations:

The Company's plant is located at Ahmednagar- Daund Road, Ahmednagar (Maharashtra).

Address for correspondence:

Shareholder's correspondence may be addressed to the Registrars & Transfer Agent, **Link Intime India Pvt. Limited**, Block No. 202, Akshay Complex, 2nd floor, Dhole Patil Road, Pune - 411001. Shareholders holding shares in electronic mode should address all their correspondence to their respective Depository Participants. Investor grievances, queries, etc. can be additionally marked to kelinvestors@kineticindia.com

**For and on behalf of the Board of Directors
For Kinetic Engineering Limited**

CERTIFICATE ON COMPLIANCE WITH CODE OF CONDUCT

I, Ajinkya A. Firodia, Managing Director of the Company hereby declare that the all the members of the Board of Directors and Senior Management Personnel have affirmed their compliance with the 'Code of Conduct for Members of the Board and Senior Management' in respect of financial year 2019-20 in terms of Para D of Schedule V of SEBI (Listing Obligations and Disclosure Requirements) Regulations, 2015.

**On behalf of the board
For Kinetic Engineering Limited**

**Ajinkya A. Firodia
Managing Director & CFO
(DIN: 00332204)**

**Date: 20th October, 2020
Place: Pune**

CEO & CFO CERTIFICATION

The Chief Executive Officer and Chief Financial Officer have furnished a Compliance Certificate to the Board of Directors under Regulation 17(8) read with Part B of Schedule II of SEBI (Listing Obligations and Disclosure Requirements) Regulations, 2015.

**Chaitanya Koranne
Chief Executive Officer**

**Ajinkya A. Firodia
Managing Director & CFO
(DIN: 00332204)**

**Date: 20th October, 2020
Place: Pune**

CERTIFICATE OF NON-DISQUALIFICATION OF DIRECTORS
(Pursuant to Regulation 34(3) and Schedule V Para C Clause (10)(i) of the SEBI (Listing Obligations and Disclosure Requirements) Regulations, 2015

To

The Members,
Kinetic Engineering Limited
D1 Block, Plot No.18/2,MIDC Chinchwad
PUNE MH 411019

I have examined the relevant registers, records, forms, returns and disclosures received from the Directors of Kinetic Engineering Limited having CIN L35912MH1970PLC014819 and having registered office at D1 Block, Plot No.18/2, MIDC, Chinchwad, PUNE MH 411019 and (hereinafter referred to as 'the Company'), produced before me by the Company for the purpose of issuing this Certificate, in accordance with Regulation 34(3) read with Schedule V Para-C Sub clause 10(i) of the Securities Exchange Board of India (Listing Obligations and Disclosure Requirements) Regulations, 2015.

In my opinion and to the best of my information and according to the verifications (including Directors Identification Number (DIN) status at the portal www.mca.gov.in) as considered necessary and explanations furnished to me by the Company & its officers, I hereby certify that none of the Directors on the Board of the Company as stated below for the Financial Year ending on 31st March, 2020 have been debarred or disqualified from being appointed or continuing as Directors of companies by the Securities and Exchange Board of India, Ministry of Corporate Affairs or any such other Statutory Authority.

| Sr. No. | DIN | Name | Date of appointment |
|---------|----------|--------------------------|---------------------|
| 1 | 00052851 | Sulajja Firodia Motwani | 04/05/1996 |
| 2 | 00057324 | Arun Hastimal Firodia | 01/07/1987 |
| 3 | 00170659 | Shirish Ratanlal Kotecha | 27/11/1987 |
| 4 | 00306688 | Ramesh Jankiram Kabra | 28/06/2014 |
| 5 | 00328499 | Jayashree Arun Firodia | 27/10/2017 |
| 6 | 00332204 | Ajinkya Arun Firodia | 06/04/2009 |
| 7 | 00392438 | Rajiv Ishwarlal Ranka | 17/07/2019 |
| 8 | 00590469 | Rohit Prakash Bafana | 13/02/2019 |

Ensuring the eligibility of for the appointment / continuity of every Director on the Board is the responsibility of the management of the Company. Our responsibility is to express an opinion on these based on our verification. This certificate is neither an assurance as to the future viability of the Company nor of the efficiency or effectiveness with which the management has conducted the affairs of the Company.

For **Dinesh Birla & Associates**
Company Secretary

Dinesh Birla
Proprietor
Membership No.: F7658
CP No. : 13029

Date : 25th June, 2020

UDIN : F007658B000380954

AUDITOR'S CERTIFICATE ON CORPORATE GOVERNANCE

To the Members

Kinetic Engineering Limited

This certificate is issued in accordance with the terms of our engagement with Kinetic Engineering Limited ('the Company').

We have examined the compliance of conditions of Corporate Governance by the Company, for the year ended on March 31, 2020, as stipulated in regulations 17 to 27 and clauses (b) to (i) of regulation 46(2) and para C and D of Schedule V of the SEBI (Listing Obligations and Disclosure Requirements) Regulations, 2015 (the Listing Regulations).

MANAGEMENTS' RESPONSIBILITY

The compliance of conditions of Corporate Governance is the responsibility of the Management. This responsibility includes the design, implementation and maintenance of internal control and procedures to ensure the compliance with the conditions of the Corporate Governance stipulated in Listing Regulations.

AUDITOR'S RESPONSIBILITY

Our responsibility is limited to examining the procedures and implementation thereof, adopted by the Company for ensuring compliance with the conditions of the Corporate Governance. It is neither an audit nor an expression of opinion on the financial statements of the Company.

We have examined the books of account and other relevant records and documents maintained by the Company for the purposes of providing reasonable assurance on the compliance with Corporate Governance requirements by the Company.

We have carried out an examination of the relevant records of the Company in accordance with the Guidance Note on Certification of Corporate Governance issued by the Institute of Chartered Accountants of India (the ICAI), the Standards on Auditing specified under Section 143(10) of the Companies Act 2013, in so far as applicable for the purpose of this certificate and as per the Guidance Note on Reports or Certificates for Special Purposes issued by the ICAI which requires that we comply with the ethical requirements of the Code of Ethics issued by the ICAI.

We have complied with the relevant applicable requirements of the Standard on Quality Control (SQC) 1, Quality Control for Firms that Perform Audits and Reviews of Historical Financial Information, and Other Assurance and Related Services Engagements.

OPINION

Based on our examination of the relevant records and according to the information and explanations provided to us and the representations provided by the Management, we certify that the Company has complied with the conditions of Corporate Governance as stipulated in regulations 17 to 27 and clauses (b) to (i) of regulation 46(2) and para C and D of Schedule V of the Listing Regulations during the year ended March 31, 2020.

We state that such compliance is neither an assurance as to the future viability of the Company nor the efficiency or effectiveness with which the Management has conducted the affairs of the Company.

For Pawan Jain and Associates
Chartered Accountants
Firm's Registration No.: 0107867W

Pawan Jain
Partner
Membership No.: 032900
UDIN : 20032900AAAACF5664

Place: Pune

Date: 16th October, 2020

INDEPENDENT AUDITOR'S REPORT

TO THE MEMBERS OF
KINETIC ENGINEERING LIMITED

Opinion

We have audited the standalone financial statements of Kinetic Engineering Limited ("the Company"), which comprise the Balance Sheet as at March 31, 2020, and the Statement of Profit and Loss (including other comprehensive income), Statement of Changes in Equity and Statement of Cash Flows for the year then ended, and notes to the standalone financial statements, including summary of significant accounting policies and other explanatory information (hereinafter referred to as "the standalone financial statements").

In our opinion and to the best of our information and according to the explanations given to us, the aforesaid standalone financial statements give the information required by the Companies Act, 2013 ("the Act") in the manner so required and give a true and fair view in conformity with the accounting principles generally accepted in India including Indian Accounting Standards ('Ind AS') specified under section 133 of the Act, of the state of affairs (financial position) of the Company as at March 31, 2020, and its loss (financial performance including other comprehensive income), its changes in equity and cash flows for the year ended on that date.

Emphasis of Matter

We draw attention to the following matters in the Notes to the Standalone Financial Statements:

Refer Note- 44 describing the basis of company's ability to continue as a Going Concern.

Our opinion is not modified in respect of the above mentioned matters.

Basis for Opinion

We conducted our audit in accordance with the Standards on Auditing (SAs) specified under Section 143(10) of the Act. Our responsibilities under those SAs are further described in the Auditor's Responsibilities for the Audit of the Standalone Financial Statements section of our report. We are independent of the Company in accordance with the Code of Ethics issued by the Institute of Chartered Accountants of India together with the ethical requirements that are relevant to our audit of the standalone financial statements under the provisions of the Act and the Rules there under, and we have fulfilled our other ethical responsibilities in accordance with these requirements and the Code of Ethics. We believe that the audit evidence we have obtained is sufficient and appropriate to provide a basis for our opinion.

Key Audit Matters

Key audit matters ('KAM') are those matters that, in our professional judgment, were of most significance in our audit of the standalone financial statements of the current period. These matters were addressed in the context of our audit of the standalone financial statements as a whole, and in forming our opinion thereon, and we do not provide a separate opinion on these matters.

We have determined the matter described below to be the key audit matters to be communicated in our report.

| The key audit matters | How our audit addressed the key audit matter |
|--|--|
| <p>Revenue recognition:</p> <p>The Company is engaged in manufacture and supply of automotive components to its customers both in domestic and international markets. Effective April 01, 2018 company has applied Ind As-115 accordingly Revenue is recognised upon transfer of control of promised products and services to customers. (refer note-2.6 to standalone financial statements).</p> <p>Ind AS 115 has been implemented starting from 1 April 2018. As a consequence, the Company has analysed its various sales contracts and concluded on the principles for determining the point of time for recognition of revenue from the Company's sales transactions.</p> <p>In view of the comprehensive change of the accounting standard applicable for the revenue and the re-evaluation of all contracts in this light, this aspect has been identified for enhanced attention in the audit.</p> | <p>Principal audit procedures:</p> <p>Our audit included but was not limited to the following activities:</p> <p>Control testing:</p> <ul style="list-style-type: none"> • Mapped and evaluated selected systems and processes for revenue recognition and tested a sample of key controls. <p>Test of details:</p> <ul style="list-style-type: none"> • Evaluated the Company's procedure in place for implementing Ind AS 115 and assessed whether Company's accounting principles comply with the new accounting standard. • Tested a sample of sales transactions for compliance with the Company's accounting principles. • Performed data analytical procedures to identify and evaluate a sample of manual journal entries. • Traced disclosure information to accounting records and other supporting documentation. |

Other Information

The Company's management and Board of Directors are responsible for the other information. The other information comprises the information included in the Company's annual report, but does not include the standalone financial statements and our auditors' report thereon.

Our opinion on the standalone financial statements does not cover the other information and we do not express any form of assurance/conclusion thereon. In connection with our audit of the standalone financial statements, our responsibility is to read the other information and, in doing so, consider whether the other information is materially inconsistent with the standalone financial statements or our knowledge obtained in the audit or otherwise appears to be materially misstated. If, based on the work we have performed, we conclude that there is a material misstatement of this other information, we are required to report that fact. We have nothing to report in this regard.

Management's Responsibility for the Standalone Financial Statements

The Company's management and Board of Directors are responsible for the matters stated in Section 134(5) of the Act with respect to the preparation of these standalone financial statements that give a true and fair view of the state of affairs (financial position), profit or loss (financial performance including other comprehensive income), changes in equity and cash flows of the Company in accordance with the accounting principles generally accepted in India, including the Indian Accounting Standards (Ind AS) specified under Section 133 of the Act. This responsibility also includes maintenance of adequate accounting records in accordance with the provisions of the Act for safeguarding of the assets of the Company and for preventing and detecting frauds and other irregularities; selection and application of appropriate accounting policies; making judgments and estimates that are reasonable and prudent; and design, implementation and maintenance of adequate internal financial controls that were operating effectively for ensuring the accuracy and completeness of the accounting records, relevant to the preparation and presentation of the standalone financial statements that give a true and fair view and are free from material misstatement, whether due to fraud or error.

In preparing the standalone financial statements, management and Board of Directors are responsible for assessing the Company's ability to continue as a going concern, disclosing, as applicable, matters related to going concern and using the going concern basis of accounting unless management either intends to liquidate the Company or to cease operations, or has no realistic alternative but to do so. Board of Directors is also

responsible for overseeing the Company's financial reporting process.

Auditor's Responsibilities for the Audit of the Standalone Financial Statements

Our objectives are to obtain reasonable assurance about whether the standalone financial statements as a whole are free from material misstatement, whether due to fraud or error, and to issue an auditor's report that includes our opinion. Reasonable assurance is a high level of assurance, but is not a guarantee that an audit conducted in accordance with SAs will always detect a material misstatement when it exists. Misstatements can arise from fraud or error and are considered material if, individually or in the aggregate, they could reasonably be expected to influence the economic decisions of users taken on the basis of these standalone financial statements. As part of an audit in accordance with SAs, we exercise professional judgment and maintain professional skepticism throughout the audit. We also:

- Identify and assess the risks of material misstatement of the standalone financial statements, whether due to fraud or error, design and perform audit procedures responsive to those risks, and obtain audit evidence that is sufficient and appropriate to provide a basis for our opinion. The risk of not detecting a material misstatement resulting from fraud is higher than for one resulting from error, as fraud may involve collusion, forgery, intentional omissions, misrepresentations, or the override of internal control.
- Obtain an understanding of internal control relevant to the audit in order to design audit procedures that are appropriate in the circumstances. Under Section 143(3)(i) of the Act, we are also responsible for expressing our opinion on whether the company has adequate internal financial controls with reference to standalone financial statements in place and the operating effectiveness of such controls.
- Evaluate the appropriateness of accounting policies used and the reasonableness of accounting estimates and related disclosures made by management.
- Conclude on the appropriateness of management's use of the going concern basis of accounting and, based on the audit evidence obtained, whether a material uncertainty exists related to events or conditions that may cast significant doubt on the Company's ability to continue as a going concern. If we conclude that a material uncertainty exists, we are required to draw attention in our auditor's report to the related disclosures in the standalone financial statements or, if such disclosures are inadequate, to modify our opinion. Our conclusions are based on the audit evidence obtained up to the date of our auditors' report. However, future events or conditions may cause the Company to cease to continue as a going concern.

- Evaluate the overall presentation, structure and content of the standalone financial statements, including the disclosures, and whether the standalone financial statements represent the underlying transactions and events in a manner that achieves fair presentation.

We communicate with those charged with governance regarding, among other matters, the planned scope and timing of the audit and significant audit findings, including any significant deficiencies in internal control that we identify during our audit.

We also provide those charged with governance with a statement that we have complied with relevant ethical requirements regarding independence, and to communicate with them all relationships and other matters that may reasonably be thought to bear on our independence, and where applicable, related safeguards.

From the matters communicated with those charged with governance, we determine those matters that were of most significance in the audit of the standalone financial statements of the current period and are therefore the key audit matters. We describe these matters in our auditors' report unless law or regulation precludes public disclosure about the matter or when, in extremely rare circumstances, we determine that a matter should not be communicated in our report because the adverse consequences of doing so would reasonably be expected to outweigh the public interest benefits of such communication.

Report on Other Legal and Regulatory Requirements

1. As required by the Companies (Auditors' Report) Order, 2016 ("the Order") issued by the Central Government of India in terms of Section 143(11) of the Act, we give in "Annexure A" a statement on the matters specified in paragraphs 3 and 4 of the Order, to the extent applicable.
- A. As required by Section 143(3) of the Act, we report that:
 - (a.) We have sought and obtained all the information and explanations which to the best of our knowledge and belief were necessary for the purposes of our audit.
 - (b.) In our opinion, proper books of account as required by law have been kept by the Company so far as it appears from our examination of those books.
 - (c.) The Balance Sheet, the Statement of Profit and Loss (including other comprehensive income), the Statement of Changes in Equity and the Statement of Cash Flows dealt with by this Report are in agreement with the books of account.
 - (d.) In our opinion, the aforesaid standalone financial statements comply with the Ind AS specified under Section 133 of the Act.

- (e.) On the basis of the written representations received from the directors as on March 31, 2020 taken on record by the Board of Directors, none of the directors is disqualified as on March 31, 2020 from being appointed as a director in terms of Section 164(2) of the Act.
- (f.) With respect to the adequacy of the internal financial controls with reference to financial statements of the Company and the operating effectiveness of such controls, refer to our separate Report in "Annexure B".
- (g.) With respect to the other matters to be included in the Auditors' Report in accordance with Rule 11 of the Companies (Audit and Auditors) Rules, 2014, in our opinion and to the best of our information and according to the explanations given to us:
 - i. The Company has disclosed the impact of pending litigations as at March 31, 2020 on its financial position in its standalone financial statements - Refer Note 38;
 - ii. The Company did not have any long-term contracts, including derivative contracts for which there were any material foreseeable losses as at 31 March 2020;
 - iii. There has been no amount required to be transferred to the Investor Education and Protection Fund by the Company during the year ended 31 March 2020;

For Pawan Jain And Associates
Chartered Accountants

Firm's Registration No.: 0107867W

Pawan Jain
Partner

Pune
30th June, 2020

Membership No.: 032900

Annexure "A" to the Independent Auditor's Report

(Referred to in paragraph 1 under the heading, "Report on Other Legal and Regulatory Requirements" of our report on even date).

Based on the audit procedures performed for the purpose of reporting a true and fair view on the financial statements of the Company and taking into consideration the information and explanations given to us and the books of account and other records examined by us in the normal course of audit, and to the best of our knowledge and belief, we report that:

- i. (a) The Company has maintained proper records showing full particulars, including quantitative details and situation of fixed assets.
- (b) As informed to us, the fixed assets are been physically verified by the management at regular intervals based on the programme of verification which in our opinion is reasonable. All the major fixed assets have been verified by the management in the current year and discrepancies noticed on such physical verification were not material and the same have been properly dealt with in the books of account.
- (c) According to the information and explanations given to us and the records examined by us and based on the examination of the registered sale deed / transfer deed / conveyance deed provided to us, we report that, the title deeds, comprising all the immovable properties of land and buildings which are freehold, are held in the name of the Company as at the balance sheet date.

In respect of immovable properties been taken on lease and disclosed as property, plant and equipment in the standalone financial statements, the lease agreements are in the name of the Company, where the Company is the lessee in the agreement.
- ii. Physical verification of inventory has been conducted by the management during the current year. In our opinion, the interval of such verification is reasonable. As informed to us, discrepancies noticed on physical verification were not material and the same have been properly dealt with in the books of account.
- iii. The company has not granted any loans, secured or unsecured to Companies, Firms, Limited Liability Partnerships or other parties covered in the register maintained under section 189 of the Companies Act,

2013. Therefore, clause (iii) a, b and c of the Order are not applicable to the Company.

- iv. According to the information and explanations provided to us, in respect of loans, investments, guarantees, and security; provisions of section 185 and 186 of the Companies Act, 2013 have been complied with wherever applicable.
- v. According to information and explanation provided to us, the Company has not accepted deposits, hence the directives issued by the Reserve Bank of India and the provisions of sections 73 to 76 or any other relevant provisions of the Companies Act and the rules framed there under, are not applicable to the Company. According to information and explanation provided to us, no order has been passed by Company Law Board or National Company Law Tribunal or Reserve Bank of India or any court or any other tribunal.
- vi. As informed to us, the cost records, pursuant to the rules made by the Central Government for the maintenance of cost records under sub-section (1) of section 148 of the Companies Act 2013 are not applicable to the company.
- vii. (a) According to the records of the company, it is generally regular in depositing undisputed statutory dues of, provident fund, employees' state insurance, income-tax, goods and service tax, duty of customs, cess and any other statutory dues with the appropriate authorities except depositing dues of Provident Fund where there are delays.

According to the information and explanation provided to us, undisputed amounts payable in respect of Provident Fund amounting to Rs. 5.80 Lakhs was in arrears as at March 31, 2020 for a period of more than six months from the date they became payable.

- (b) According to the information and explanation provided to us, there are no dues of Income-tax or Sales tax or Service tax or Goods and Service tax or duty of Customs or duty of Excise or Value added tax or entry tax, which have not been deposited by the Company on account of disputes, except for the following:

| Nature of Dues | Amount in (Rs) Lacs | Forum where dispute is pending |
|--|----------------------------|---|
| Income Tax 2000-01 | 1.29 | ITAT, Pune |
| Income Tax 2009-10 | 186.12 | CIT Appeals Pune |
| Income Tax 2011-12 | 0.24 | CIT Appeals Pune |
| CST 1994-95, 99-00, 00-01, 02-03, 03-04, 08-09, 07-08, 09-10 | 56.58 | Appellate Dy. Commissioner commercial Tax, Indore |
| CST 1998-99, 2001-02 | 27.27 | Appellate Dy. Commissioner commercial Tax, Indore |
| CST (Pune) 2014-15 | 7.76 | Dy. Commissioner Sales tax, Pune |
| Entry Tax 1994-95, 95-96, 2007-08 | 8.41 | Dy. Commissioner Commercial Tax, Indore |
| MP Commercial Tax 1998-99 | 1.88 | Appellate Dy. Commissioner commercial Tax, Indore |
| MP Commercial Tax 1999-00, 2007-08, 2008-09 | 9.16 | Appellate Dy. Commissioner commercial Tax, Indore |
| VAT (Pune) 2014-15 | 34.76 | Dy. Commissioner Sales tax, Pune |
| Excise Duty | 171.19 | CESTAT, Mumbai and Nagpur |

- viii. Based on our Audit procedures and according to the information and explanation provided to us, the Company has not defaulted in repayment of dues to a financial institution, bank or government. The Company does not have any debenture holders.
- ix. According to information and explanation provided to us, the Company has not raised moneys by way of initial public offer or further public offer (including debt instruments). The Company has raised moneys by way of term loans from the bank during the year and were applied for the purposes for which those are raised.
- x. Based upon the Audit procedures performed by us and according to the information and explanations provided to us by the management, no fraud by the Company or any fraud on the Company by its officers or employees has been noticed or reported to us during the year.
- xi. In our opinion and according to the information and explanations given to us and based on examination of the records of the Company, the Company has paid / provided managerial remuneration in accordance with the requisite approvals mandated by the provisions of Section 197 read with Schedule V to the Act.
- xii. The Company is not a Nidhi Company and accordingly, Clause (xii) of the Order is not applicable to the Company.
- xiii. According to the information and explanation provided to us, all transactions with the related parties are in compliance with sections 177 and
- 188 of Companies Act, 2013 wherever applicable and the details have been disclosed in the Standalone Financial Statements as required by the applicable Indian Accounting Standards.
- xiv. During the year the Company has not made any preferential allotment or private placement of shares or fully or partly convertible debentures and hence reporting under clause (xiv) of the Order is not applicable to the Company.
- xv. According to the information and explanation provided to us, the Company has not entered into any non-cash transactions with directors or persons connected with him.
- xvi. According to the information and explanation provided to us, the Company is not required to be registered under section 45-IA of the Reserve Bank of India Act, 1934.

For Pawan Jain And Associates
Chartered Accountants
 Firm's Registration No.: 0107867W

Pawan Jain
 Partner
 Membership No.: 032900

Pune
 30th June, 2020

Annexure “B” to the Independent Auditor’s Report

(Referred to in paragraph 1(A) (f) under the heading, “Report on Other Legal and Regulatory Requirements” of our report on even date)

Report on the Internal Financial Controls Over Financial Reporting under Clause (i) of Sub-section 3 of Section 143 of the Companies Act, 2013 (“the Act”)

We have audited the internal financial controls over financial reporting of **Kinetic Engineering Limited** (the “Company”) as of March 31, 2020 in conjunction with our audit of the Standalone Financial Statements of the Company for the year ended on that date.

Management’s Responsibility for Internal Financial Controls

The Company’s management is responsible for establishing and maintaining internal financial controls based on the internal control over financial reporting criteria established by the Company considering the essential components of internal control stated in the Guidance Note on Audit of Internal Financial Controls Over Financial Reporting issued by the Institute of Chartered Accountants of India (“ICAI”). These responsibilities include the design, implementation and maintenance of adequate internal financial controls that were operating effectively for ensuring the orderly and efficient conduct of its business, including adherence to respective company’s policies, the safeguarding of its assets, the prevention and detection of frauds and errors, the accuracy and completeness of the accounting records, and the timely preparation of reliable financial information, as required under the Act.

Auditor’s Responsibility

Our responsibility is to express an opinion on the Company’s internal financial controls over financial reporting of the Company based on our audit. We conducted our Audit in accordance with the Guidance Note on Audit of Internal Financial Controls Over Financial Reporting (the “Guidance Note”) issued by the Institute of Chartered Accountants of India and the Standards on Auditing prescribed under Section 143(10) of the Companies Act, 2013, to the extent applicable to an Audit of internal financial controls. Those Standards and the Guidance Note require that we comply with ethical requirements and plan and perform the Audit to obtain reasonable assurance about whether adequate internal financial controls over financial reporting was established and maintained and if such controls operated effectively in all material respects.

Our Audit involves performing procedures to obtain Audit evidence about the adequacy of the internal financial controls system over financial reporting and their operating effectiveness. Our Audit of internal financial controls over

financial reporting included obtaining an understanding of internal financial controls over financial reporting, assessing the risk that a material weakness exists, and testing and evaluating the design and operating effectiveness of internal control based on the assessed risk. The procedures selected depend on the Auditor’s judgement, including the assessment of the risks of material misstatement of the financial statements, whether due to fraud or error.

We believe that the Audit evidence we have obtained is sufficient and appropriate to provide a basis for our Audit opinion on the Company’s internal financial controls system over financial reporting.

Meaning of Internal Financial Controls over Financial Reporting

A company’s internal financial control over financial reporting is a process designed to provide reasonable assurance regarding the reliability of financial reporting and the preparation of financial statements for external purposes in accordance with generally accepted accounting principles. A company’s internal financial control over financial reporting includes those policies and procedures that (1) pertain to the maintenance of records that, in reasonable detail, accurately and fairly reflect the transactions and dispositions of the assets of the company; (2) provide reasonable assurance that transactions are recorded as necessary to permit preparation of financial statements in accordance with generally accepted accounting principles, and that receipts and expenditures of the company are being made only in accordance with authorisations of management and directors of the company; and (3) provide reasonable assurance regarding prevention or timely detection of unauthorised acquisition, use, or disposition of the company’s assets that could have a material effect on the financial statements.

Inherent Limitations of Internal Financial Controls over Financial Reporting

Because of the inherent limitations of internal financial controls over financial reporting, including the possibility of collusion or improper management override of controls, material misstatements due to error or fraud may occur and not be detected. Also, projections of any evaluation of the internal financial controls over financial reporting to future periods are subject to the risk that the internal financial control over financial reporting may become inadequate because of changes in conditions, or that the degree of compliance with the policies or procedures may deteriorate.

Opinion

In our opinion, to the best of our information and according to the explanations given to us, the Company has, in all material respects, an adequate internal financial controls system over financial reporting and such internal financial controls over financial reporting were operating effectively as at March 31, 2020, based on the criteria for internal financial control over financial reporting established by Company considering the essential components of internal control stated in the Guidance Note on Audit of Internal Financial Controls Over Financial Reporting issued by the ICAI.

For **Pawan Jain And Associates**

Chartered Accountants

Firm's Registration No.: 0107867W

Pawan Jain

Partner

Pune

30th June, 2020

Membership No.: 032900

Balance Sheet as at 31st March, 2020

(INR in Lakhs)

| PARTICULARS | Note | 31st March, 2020 | 31st March, 2019 |
|---|------|------------------|------------------|
| ASSETS | | | |
| 1) Non-current assets | | | |
| a) Property, Plant & Equipment | 3 | 7,756.56 | 8,294.14 |
| b) Capital work-in-progress | | - | - |
| c) Other Intangible Assets | 3 | 3.12 | 8.27 |
| d) Financial Assets | | | |
| (i) Investments | 4 | 542.29 | 649.62 |
| (ii) Other | 5 | 454.57 | 454.51 |
| e) Deferred Tax Assets | 6 | - | - |
| f) Other Non-Current Assets | 7 | 61.03 | 63.98 |
| | | 8,817.57 | 9,470.52 |
| 2) Current assets | | | |
| a) Inventories | 8 | 2,977.81 | 3,107.25 |
| b) Financial Assets | | | |
| (i) Investments | 4 | 0.11 | 0.11 |
| (ii) Trade receivables | 9 | 2,364.94 | 2,858.97 |
| (iii) Cash and cash equivalents | 10 | 72.66 | 34.02 |
| (iv) Bank Balances other than (iii) above | 11 | 11.80 | 11.42 |
| (v) Loans | 12 | 3.65 | 3.65 |
| (vi) Others | 13 | 5.20 | 5.04 |
| c) Current Tax Assets(Net) | 14 | 151.22 | 139.07 |
| d) Other current assets | 15 | 382.33 | 475.74 |
| | | 5,969.71 | 6,635.27 |
| | | 14,787.28 | 16,105.79 |
| TOTAL | | | |
| EQUITY AND LIABILITIES | | | |
| Equity | | | |
| a) Share Capital | 16 | 1,770.86 | 1,770.86 |
| b) Other Equity | 17 | -388.86 | 553.59 |
| | | 1,382.00 | 2,324.45 |
| Liabilities | | | |
| 1) Non-current liabilities | | | |
| a) Financial Liabilities | | | |
| (i) Borrowings | 18 | 3,453.93 | 3,478.72 |
| b) Provisions | 19 | 490.74 | 538.00 |
| c) Other Non-Current Liabilities | 20 | 1,061.00 | 1,281.09 |
| | | 5,005.67 | 5,297.81 |
| 2) Current liabilities | | | |
| a) Financial Liabilities | | | |
| (i) Borrowings | 21 | 2,464.97 | 2,333.37 |
| (ii) Trade payables | 22 | 4,046.43 | 4,379.80 |
| (iii) Others | 23 | 949.97 | 1,003.32 |
| b) Provision | 25 | 538.24 | 439.65 |
| c) Other Current Liabilities | 24 | 400.00 | 327.39 |
| | | 8,399.61 | 8,483.53 |
| | | 14,787.28 | 16,105.79 |
| TOTAL | | | |

 Summary of significant accounting policies
 Notes are integral part of the financial statements

2

 As per our report of even date
 For **Pawan Jain And Associates**
 Chartered Accountants

Pawan Jain
 Partner
 Membership Number- 032900
 Firm Reg No.:0107867W

 Place : Pune
 Date : 30th June, 2020

 For and on behalf of Board of Directors
 For **Kinetic Engineering Limited**
A. H. Firodia
 (Chairman)
 DIN:00057324

A. A Firodia
 (Managing Director & CFO)
 DIN:00332204

Chaitanya Koranne **Nikhil Deshpande**
 (Chief Executive Officer) (Company Secretary)

Statement of Profit and Loss for the year ended 31st March, 2020

(INR in Lakhs)

| PARTICULARS | Note | 31st March, 2020 | 31st March, 2019 |
|--|-------------|-----------------------------|-----------------------------|
| INCOME : | | | |
| a) Revenue from Operations | 26 | 11,574.70 | 11,577.35 |
| b) Other income | 27 | 275.16 | 474.12 |
| Total Income | | 11,849.86 | 12,051.47 |
| EXPENSES : | | | |
| a) Cost of materials consumed | 28 | 6,192.24 | 7,065.78 |
| b) Changes in inventories of finished goods and work-in-progress | 29 | 124.23 | (524.34) |
| c) Employee benefits expenses | 30 | 2,476.46 | 2,528.27 |
| d) Finance costs | 31 | 660.38 | 598.22 |
| e) Depreciation and amortization expenses | 3 | 721.26 | 734.41 |
| f) Other expenses | 32 | 2,587.04 | 2,465.48 |
| Total Expenses | | 12,761.60 | 12,867.83 |
| Profit/(Loss) before exceptional items and tax | | (911.74) | (816.36) |
| Exceptional items | | - | - |
| Profit/(Loss) before tax | | (911.74) | (816.36) |
| Tax expenses : | | | |
| a) Current tax | | - | - |
| b) Deferred tax | | - | - |
| Profit (Loss) for the year | | (911.74) | (816.36) |
| Other Comprehensive Income | | | |
| Items that will not be reclassified to Profit or Loss | | | |
| (i) Re-measurement of net defined benefit plan | | (30.71) | (64.83) |
| (ii) Income Tax Effect | | - | - |
| Total Other Comprehensive Income | | (30.71) | (64.83) |
| Total Comprehensive Income for the year | | (942.45) | (881.19) |
| Earnings Per Share (Nominal value per share Rs. 10) | | | |
| Basic | | (5.32) | (4.98) |
| Diluted | | (5.32) | (4.98) |

 Summary of significant accounting policies
 Notes are integral part of the financial statements

2

 As per our report of even date
 For **Pawan Jain And Associates**
 Chartered Accountants

Pawan Jain
 Partner
 Membership Number- 032900
 Firm Reg No.:0107867W

 Place : Pune
 Date : 30th June, 2020

 For and on behalf of Board of Directors
 For **Kinetic Engineering Limited**
A. H. Firodia
 (Chairman)
 DIN:00057324

A. A Firodia
 (Managing Director & CFO)
 DIN:00332204

Chaitanya Koranne **Nikhil Deshpande**
 (Chief Executive Officer) (Company Secretary)

Statement of changes in equity for the year ended 31st March, 2020

A. Equity share capital (INR in Lakhs)

| PARTICULARS | Number | Amount |
|---------------------------------|------------|----------|
| As at April 01, 2018 | 17,708,621 | 1,770.86 |
| Changes in equity share capital | - | - |
| As at March 31, 2019 | 17,708,621 | 1,770.86 |
| Change in equity share capital | - | - |
| As at March 31, 2020 | 17,708,621 | 1,770.86 |

B. Other equity (INR in Lakhs)

| PARTICULARS | Preference Shares | Capital Reserve | Securities premium reserve | General reserve | Special Reserve | Retained Earnings/ Surplus | Other Compre -hensive Income | Total |
|---|-------------------|-----------------|----------------------------|-----------------|-----------------|----------------------------|------------------------------|----------|
| As at April 01, 2018 | 1,963.52 | 3,535.19 | 9,384.06 | 8,669.25 | 0.46 | (22,085.94) | (30.83) | 1,435.70 |
| Increase/ (Decrease) Profit/(Loss) for the year | - | - | - | - | - | (0.92) | (64.83) | (65.75) |
| Changes during the year | - | - | - | - | - | (816.36) | - | (816.36) |
| As at March 31, 2019 | 1,963.52 | 3,535.19 | 9,384.06 | 8,669.25 | 0.46 | (817.28) | (64.83) | (882.11) |
| | | | | | | | | 553.59 |

| PARTICULARS | Preference Shares | Capital Reserve | Securities premium reserve | General reserve | Special Reserve | Retained Earnings/ Surplus | Other Compre -hensive Income | Total |
|---|-------------------|-----------------|----------------------------|-----------------|-----------------|----------------------------|------------------------------|----------|
| As at April 01, 2019 | 1,963.52 | 3,535.19 | 9,384.06 | 8,669.25 | 0.46 | (22,903.22) | (95.66) | 553.59 |
| Increase/ (Decrease) Profit/(Loss) for the year | - | - | - | - | - | - | (30.71) | (30.71) |
| Changes during the year | - | - | - | - | - | (911.74) | - | (911.74) |
| Balance as at March 31, 2020 | 1,963.52 | 3,535.19 | 9,384.06 | 8,669.25 | 0.46 | (911.74) | (30.71) | (942.45) |
| | | | | | | | | (388.86) |

As per our report of even date
For **Pawan Jain And Associates**
Chartered Accountants

Pawan Jain

Partner

Membership Number- 032900

Firm Reg No.:0107867W

Place : Pune

Date : 30th June, 2020

For and on behalf of Board of Directors
For **Kinetic Engineering Limited**

A. H. Firodia
(Chairman)
DIN:00057324

A. A Firodia
(Managing Director & CFO)
DIN:00332204

Chaitanya Koranne
(Chief Executive Officer)

Nikhil Deshpande
(Company Secretary)

Statement of Cash Flows For the period ended 31st March, 2020
(INR in Lakhs)

| PARTICULARS | 31st March, 2020 | 31st March, 2019 |
|---|------------------|------------------|
| A. CASH FLOW FROM OPERATING ACTIVITIES | | |
| Net Profit / (Loss) for the year | (942.45) | (881.19) |
| Adjustment For : | | |
| Depreciation | 721.26 | 734.41 |
| Interest & Finance charges (Net) | 438.83 | 367.14 |
| Dividend Received | (3.97) | (3.65) |
| Excess provision / credit balances written back | - | (67.37) |
| Unrealised gain on fair valuation of Investment | (11.81) | 0.03 |
| Unrealised Exchange difference loss / (gain) | (54.40) | 18.54 |
| Profit (-) / Loss (+) on sale of Investments | - | - |
| Profit (-) / Loss (+) on sale of Assets | - | (121.46) |
| Operative Profit before Working Capital Changes | 147.45 | 46.45 |
| Adjustment for net change in: | | |
| Trade and Other Receivables | 641.40 | (382.86) |
| Inventories | 129.44 | (795.61) |
| Trade & Other payables | (252.44) | 1,186.51 |
| Cash generated from operations | 665.85 | 54.49 |
| Direct Taxes | (12.15) | 34.82 |
| Net Cash Generated from operating activities | 653.69 | 89.31 |
| B. CASH FLOW FROM INVESTING ACTIVITIES | | |
| Purchase of Property, Plant & Equipment and Intangible Assets | (187.59) | (251.12) |
| Sale of Property, Plant & Equipment and Intangible Assets | - | 125.28 |
| Sale of Investment (Net) | 119.14 | 59.99 |
| Dividend received | 3.97 | 3.65 |
| Interest Received | 6.30 | 14.80 |
| Net Cash used in investing activities | (58.17) | (47.41) |
| C. CASH FLOW FROM FINANCING ACTIVITIES | | |
| Proceeds from Long Term Borrowings | (205.60) | 813.16 |
| Proceeds from Short Term Borrowings | 131.60 | (175.19) |
| Interest and Financial Charges paid | (468.88) | (441.12) |
| Redemption premium paid | (14.00) | (254.00) |
| Net Cash used in financing activities | (556.88) | (57.15) |
| D. Net change in Cash and cash equivalents (A+B+C) | 38.64 | (15.25) |
| Cash and Cash Equivalents (Opening) | 34.02 | 49.27 |
| Cash and Cash Equivalents (Closing) | 72.66 | 34.02 |

Notes : 1. Figures in brackets represent cash outflows.

2. Previous year figures have been regrouped wherever necessary.

3. Cash and cash equivalents comprises of :

| | 31st March, 2020 | 31st March, 2019 |
|---------------------|------------------|------------------|
| Cash on hand | 0.14 | 0.17 |
| Balances with banks | 72.52 | 33.86 |
| | 72.66 | 34.02 |

As per our report of even date
For **Pawan Jain And Associates**
Chartered Accountants

Pawan Jain
Partner
Membership Number- 032900
Firm Reg No.:0107867W

Place : Pune
Date : 30th June, 2020

For and on behalf of Board of Directors
For **Kinetic Engineering Limited**

A. H. Firodia
(Chairman)
DIN:00057324

A. A Firodia
(Managing Director & CFO)
DIN:00332204

Chaitanya Koranne
(Chief Executive Officer)

Nikhil Deshpande
(Company Secretary)

Notes to Financial Statements for the year ended 31st March, 2020
1. The corporate overview

Kinetic Engineering Limited ('the company') is a public limited company domiciled in India and incorporated under the provisions of Indian Companies Act. The Registered Office of the Company is situated at D-1 Block, Plot No. 18/2, MIDC, Chinchwad, Pune. The company's ordinary shares are listed on the Bombay Stock Exchange.

The company is engaged in the business of supply of automotive components. The company caters to both domestic and international markets.

2. Significant accounting policies
2.1 Statement of Compliance

The financial statements of the company comply in all material aspects with Indian Accounting Standards (Ind AS) notified under Section 133 of Companies Act, 2013 (the Act) [Companies (Indian Accounting Standards) Rules, 2015] and other relevant provisions of the Act.

The financial statements were authorised for issue by the Board of Directors at its meeting held on June 30, 2020

2.2 Basis of preparation

The financial statements have been prepared on a historical cost basis, except certain financial instruments and defined benefit plans, which are measured at fair value.

2.3 Functional and presentation currency

These financial statements are presented in Indian Rupees (INR), which is the company's functional currency. All amounts have been rounded-off to the nearest Lakhs, unless otherwise stated.

2.4 Significant accounting judgments, estimates and assumptions

The preparation of the financial statements in conformity with Ind AS requires the management to make judgments, estimates and assumptions which affect the reported amounts of revenue, expenses, current assets, non-current assets, current liabilities, non-current liabilities and disclosure of the contingent liabilities at the end of each reporting period. Actual estimates may differ from these estimates.

Detailed information about each of these estimates and judgements is included in relevant notes.

The areas involving critical estimates and judgements are:

Estimation of current tax expense and payable – Note 14

Estimation of defined benefit obligation – Note 19 & Note 25

Recognition of revenue – Note 26

Recognition of deferred tax assets for carried forward tax losses – Note 6

Useful lives of property, plant and equipment - Note 3

Impairment of trade receivables – Note 9

Estimation and underlying assumptions are reviewed on an ongoing basis. Revisions to accounting estimates are recognised in the period in which the estimate is revised and future periods affected.

2.5 Current versus non-current classification

The company presents assets and liabilities in the balance sheet based on current / non-current classification.

An asset is current when it is:

Expected to be realised or intended to be sold or consumed in normal operating cycle;

Held primarily for the purpose of trading;

Expected to be realised within twelve months after the reporting period; or

Cash or cash equivalent unless restricted from being exchanged or used to settle a liability for at least twelve months after the reporting period.

All other assets are classified as non-current.

A liability is current when:

It is expected to be settled in normal operating cycle;

It is held primarily for the purpose of trading;

It is due to be settled within twelve months after the reporting period; or

There is no unconditional right to defer the settlement of the liability for at least twelve months after the reporting period

All other liabilities are classified as non-current.

Deferred tax assets and liabilities are classified as non-current assets and liabilities.

2.6 Revenue recognition

Effective April 1, 2018, the Company has applied Ind AS 115 which establishes a comprehensive framework for determining whether, how much and when revenue is to be recognised. Ind AS 115 replaces Ind AS 18 Revenue and Ind AS 11 Construction Contracts. The standard is applied by the company prospectively and the comparative information in the statement of profit and loss is not restated – i.e. the comparative information continues to be reported under Ind AS 18 and Ind AS 11. The impact of the adoption of the standard on the financial statements of the Company is insignificant.

Revenue is recognised upon transfer of control of promised products or services to customers in an amount that reflects the consideration which the Company expects to receive in exchange for those products or services.

Revenue is measured based on the transaction price, which is the consideration, adjusted for volume discounts, service level credits, performance bonuses, price concessions and incentives, if any, as specified in the contract with the customer. Revenue also excludes taxes collected from customers.

Contract assets are recognised when there is excess of revenue earned over billings on contracts.

Contract assets are classified as unbilled receivables (only act of invoicing is pending) when there is unconditional right to receive cash, and only passage of time is required, as per contractual terms.

Unearned and deferred revenue (“contract liability”) is recognised when there is billings in excess of revenues.

Contracts are subject to modification to account for changes in contract specification and requirements. The Company reviews modification to contract in conjunction with the original contract, basis which the transaction price could be allocated to a new performance obligation, or transaction price of an existing obligation could undergo a change. In the event transaction price is revised for existing obligation, a cumulative adjustment is accounted for.

Dividend income is recorded when the right to receive payment is established. Interest income is recognised using the effective interest method.

Export benefits in the form of Duty Draw Back/ Merchandise Exports Incentive Scheme (MEIS) claims are recognised in the statement of profit and loss on receipt basis.

2.7 Inventories

Inventories are stated at the lower of cost and net realisable value. However, materials and other items held for use in the production of inventories are not written down below cost, if the finished products in which they will be incorporated are expected to be sold at or above cost. Cost is ascertained on a weighted average basis.

Cost of raw materials, components, stores and spares comprises cost of purchases. Cost of work-in-progress and finished goods comprises direct materials, direct labour and an appropriate proportion of variable and fixed overhead expenditure, the latter being allocated based on normal operating capacity. Cost of inventories also includes all other costs incurred in bringing the inventories to their present location and condition.

Net realisable value is the estimated selling price in the ordinary course of business, less estimated costs of completion and the estimated costs necessary to make the sale.

2.8 Property, plant and equipment (PPE)

Recognition and measurement

Property, plant and equipment are stated at cost comprising of purchase price and any initial directly attributable cost of bringing the asset to its working condition for its intended use, less accumulated depreciation (other than freehold land) and impairment loss, if any. Borrowing costs directly attributable to the construction of a qualifying asset are capitalised as part of the cost.

When parts of an item of property, plant and equipment have different useful lives, they are accounted for as separate items (major components) of property, plant and equipment.

Subsequent costs

The cost of replacing a part of an item of property, plant and equipment is recognised in the carrying

amount of the item if it is probable that the future economic benefits embodied within the part will flow to the company and its cost can be measured reliably. The carrying amount of the replaced part is derecognised. The costs of the day-to-day servicing of property, plant and equipment are recognised in the statement of profit and loss as incurred.

Disposal

The gain or loss arising on disposal of an item of property, plant and equipment is determined as the difference between sale proceeds and carrying value of such item, and is recognised in the statement of profit and loss.

Depreciation

Depreciation is calculated over the depreciable amount, which is the cost of an asset, or other amount substituted for cost, less its residual value.

On PPE acquired on or before 31 March 2000: Depreciation is recognised in the statement of profit and loss on a written down value basis over the estimated useful lives of each part of an item of property, plant and equipment as prescribed in Schedule II of the Companies Act, 2013, as assessed by the management of the company based on technical evaluation.

On PPE acquired after 31 March 2000: Depreciation is recognised in the statement of profit and loss on a straight line basis over the estimated useful lives of each part of an item of property, plant and equipment as prescribed in Schedule II of the Companies Act, 2013, as assessed by the management of the company based on technical evaluation.

Freehold land is not depreciated.

The property, plant and equipment acquired under finance leases is depreciated over the shorter of the lease term and their useful lives unless it is reasonably certain that the company will obtain ownership by the end of the lease term.

The estimated useful lives for main categories of property, plant and equipments are:

| Category | Useful life |
|--------------------------------------|----------------|
| Building | 30 to 60 years |
| Plant and Machinery | 15 to 25 years |
| Electrical installation and Fittings | 10 years |
| Dies, Jigs & Fixtures | 10 to 15 years |
| Furniture and Fixtures | 5 to 15 years |
| Office Equipments | 3 to 5 years |
| Vehicles | 8 to 10 years |

2.9 Intangible assets

Recognition and measurement

Intangible assets are recognised when the asset is identifiable, is within the control of the company, it is probable that the future economic benefits that are attributable to the asset will flow to the company and cost of the asset can be reliably measured.

Expenditure on research activities is recognised in the statement of profit and loss as incurred. Development expenditure is capitalised only if the

expenditure can be measured reliably, the product or process is technically and commercially feasible, future economic benefits are probable and the company intends to and has sufficient resources to complete development and to use or sell the asset.

Subsequent measurement

Subsequent expenditure is capitalised only when it increases the future economic benefits embodied in the specific asset to which it relates.

Amortisation

Amortisation is calculated over the cost of the asset, or other amount substituted for cost, less its residual value. Amortisation is recognised in statement of profit and loss on a straight-line basis over the estimated useful lives of intangible assets from the date that they are available for use, since this most closely reflects the expected pattern of consumption of the future economic benefits embodied in the asset.

The estimated useful lives are as follows:

| Asset | Useful life |
|--------------|--------------------|
| Software | 4 years |

2.10 Investment property

Property that is held for long-term rental yields or for capital appreciation or both, and that is not occupied by the company, is classified as investment property.

Investment property is measured at cost less accumulated depreciation.

2.11 Impairment of tangible and intangible assets

Property, plant and equipment and intangible assets with finite life are evaluated for recoverability whenever there is any indication that their carrying amounts may not be recoverable. If any such indication exists, the recoverable amount (i.e. higher of the fair value less cost to sell and the value in-use) is determined on an individual asset basis unless the asset does not generate cash flows that are largely independent of those from other assets. In such cases, the recoverable amount is determined for the cash generating unit (CGU) to which the asset belongs.

If the recoverable amount of an asset (or CGU) is estimated to be less than its carrying amount, the carrying amount of the asset (or CGU) is reduced to its recoverable amount. An impairment loss is recognised in the statement of profit and loss.

An impairment loss in respect of goodwill is not reversed. For other assets, an impairment loss is reversed only to the extent that the asset's carrying amount does not exceed the carrying amount that would have been determined, net of depreciation or amortisation, if no impairment loss had been recognised.

2.12 Foreign currency transactions and balances

Transactions in foreign currency are recorded at exchange rates prevailing at the date of transactions. Exchange differences arising on foreign exchange transactions settled during the year are recognised in the statement of profit and loss of the year.

Monetary assets and liabilities denominated in foreign currencies which are outstanding, as at the reporting period are translated at the closing exchange rates and the resultant exchange differences are recognised in the statement of profit and loss.

Non-monetary assets and liabilities denominated in foreign currencies that are measured in terms of historical cost are translated using the exchange rate at the date of the transaction.

2.13 Employee benefits

Short-term employee benefits

Employee benefits payable wholly within twelve months of rendering the service are classified as short-term employee benefits and are recognised in the period in which the employee renders the related service. A liability is recognised for the amount expected to be paid when there is a present legal or constructive obligation to pay this amount as a result of past service provided by the employee and the obligation can be estimated reliably.

Defined contribution plans

Contributions to defined contribution plans are recognised as expense when employees have rendered services entitling them to such benefits.

Defined benefit plans

The employees' gratuity scheme is a defined benefit plan. The present value of the obligation under such defined benefit plans is determined based on actuarial valuation using the projected unit credit method, which recognises each period of service as giving rise to additional unit of employee benefit entitlement and measures each unit separately to build up the final obligation.

The obligation is measured at the present value of the estimated future cash flows. The discount rates used for determining the present value of the obligation under defined benefit plans, is based on the market yields on government securities as at the reporting date, having maturity periods approximating to the terms of related obligations.

Remeasurements, comprising of actuarial gains and losses, the effect of the asset ceiling, excluding amounts included in net interest on the net defined benefit liability and the return on plan assets (excluding amounts included in net interest on the net defined benefit liability), are recognised immediately in the balance sheet with a corresponding debit or credit to retained earnings through other comprehensive income (OCI) in the period in which they occur. Remeasurements are not reclassified to the statement of profit and loss in subsequent periods.

In case of funded plans, the fair value of the plan's assets is reduced from the gross obligation under the defined benefit plans, to recognise the obligation on net basis.

When the benefits of the plan are changed or when a plan is curtailed, the resulting change in benefits that relates to past service or the gain or loss on curtailment is recognised immediately in the statement of profit and loss. Net interest is calculated by applying the discount rate to the net

defined benefit liability or asset. The company recognises gains/ losses on settlement of a defined plan when the settlement occurs.

Compensated absences

The liabilities for earned leave are not expected to be settled wholly within twelve months after the end of the reporting period in which the employees render the related service. They are therefore measured as the present value of expected future payments to be made in respect of services provided by employees up to the end of the reporting period using the projected unit credit method as determined by actuarial valuation. The benefits are discounted using the market yields at the end of the reporting period that have terms approximating the terms of the related obligation. Remeasurements as a result of experience adjustments and change in actuarial assumptions are recognised in the statement of profit and loss. The obligations are presented as current liabilities in the balance sheet if the entity does not have an unconditional right to defer settlement for at least twelve months after the reporting period, regardless of when the actual settlement is expected to occur.

Termination benefits

Termination benefits are expensed at the earlier of when the company can no longer withdraw the offer of those benefits and when the company recognises costs for a restructuring. If benefits are not expected to be settled wholly within 12 months of the reporting date, then they are discounted.

2.14 Leases

The determination of whether an arrangement is (or contains) a lease is based on the substance of the arrangement at the inception of the lease. The arrangement is, or contains, a lease if fulfilment of the arrangement is dependent on the use of a specific asset or assets and the arrangement conveys a right to use the asset or assets, even if that right is not explicitly specified in an arrangement.

Company as a lessee

A lease is classified at the inception date as a finance lease or an operating lease. A lease that transfers substantially all the risks and rewards incidental to ownership to the company is classified as a finance lease.

Finance leases

are capitalised at the commencement of the lease at the inception date fair value of the leased asset or, if lower, at the present value of the minimum lease payments. Lease payments are apportioned between finance charges and reduction of the lease liability to achieve a constant rate of interest on the remaining

balance of the liability. Finance charges are recognised in finance costs in the statement of profit and loss.

A leased asset is depreciated over the useful life of the asset. However, if there is no reasonable certainty that the company will obtain ownership by the end of the lease term, the asset is depreciated over the shorter of the estimated useful life of the asset and the lease term.

Operating lease

payments are recognised as an expense in the statement of profit and loss on a straight-line basis over the lease term unless the payments to the lessor are structured to increase in line with expected general inflation to compensate for the lessor's expected inflationary cost increases or another systematic basis is available.

Company as lessor

Leases in which the company does not transfer substantially all the risks and rewards of ownership of an asset are classified as operating leases. Rental income from operating lease is recognised on a straight-line basis over the term of the relevant lease unless the payments to the lessor are structured to increase in line with expected general inflation to compensate for the lessor's expected inflationary cost increases or another systematic basis is available. Initial direct costs incurred in negotiating and arranging an operating lease are added to the carrying amount of the leased asset and recognised over the lease term on the same basis as rental income. Contingent rents are recognised as revenue in the period in which they are earned.

Leases are classified as finance leases when substantially all of the risks and rewards of ownership transfer from the company to the lessee. Amounts due from lessees under finance leases are recorded as receivables at the company's net investment in the leases. Finance lease income is allocated to accounting periods to reflect a constant periodic rate of return on the net investment outstanding in respect of the lease.

2.15 Borrowing costs

Borrowing costs consist of interest and other costs that an entity incurs in connection with the borrowing of funds. Borrowing cost also includes exchange differences to the extent regarded as an adjustment to the borrowing costs.

Borrowing costs directly attributable to the acquisition, construction or production of a qualifying asset that necessarily takes a

substantial period of time to get ready for its intended use or sale are capitalised during the period of time that is required to complete and prepare the asset for its intended use or sale. All other borrowing costs are expensed in the period in which they are incurred.

2.16 Income tax

Income tax expense comprises current and deferred tax. It is recognised in the statement of profit and loss except to the extent that it relates to a business combination, or items recognised directly in equity or in OCI.

Current tax

Current tax assets and liabilities are measured at the amount expected to be recovered from or paid to the taxation authorities. The tax rates and tax laws used to compute the amount are those that are enacted, at the reporting date in the country where the company operates and generates taxable income. Current tax assets and liabilities are offset only if there is a legally enforceable right to set it off the recognised amounts and it is intended to realise the asset and settle the liability on a net basis or simultaneously.

Minimum Alternate Tax (MAT) paid in a year is charged to the statement of profit and loss as current tax. The company recognises MAT credit available as an asset only to the extent that there is convincing evidence that the company will pay normal income tax during the specified period, i.e., the period for which MAT credit is allowed to be carried forward. The company reviews the 'MAT credit entitlement' asset at each reporting date and writes down the asset to the extent the company does not have convincing evidence that it will pay normal tax during the specified period.

Deferred tax

Deferred tax is provided using the balance sheet method on temporary differences between the tax base of assets and liabilities and their carrying amounts for financial reporting purposes at the reporting date.

Deferred tax liabilities are recognised for all taxable temporary differences, except:

When the deferred tax liability arises from the initial recognition of goodwill or an asset or liability in a transaction that is not a business combination and, at the time of the transaction, affects neither the accounting profit nor taxable profit or loss; Taxable temporary differences arising on the initial recognition of goodwill.

Deferred tax assets are recognised for all deductible temporary differences, the carry forward of unused tax credits and any unused

tax losses. Deferred tax assets are recognised to the extent that it is probable that taxable profit will be available against which the deductible temporary differences, and the carry forward of unused tax credits and unused tax losses can be utilised, except:

When the deferred tax asset relating to the deductible temporary difference arises from the initial recognition of an asset or liability in a transaction that is not a business combination and, at the time of the transaction, affects neither the accounting profit nor taxable profit or loss.

The carrying amount of deferred tax assets is reviewed at each reporting date and reduced to the extent that it is no longer probable that sufficient taxable profit will be available to allow all or part of the deferred tax asset to be utilised. Unrecognised deferred tax assets are re-assessed at each reporting date and are recognised to the extent that it has become probable that future taxable profits will allow the deferred tax asset to be recovered.

Deferred tax assets and liabilities are measured at the tax rates that are expected to apply in the year when the asset is realised or the liability is settled, based on tax rates (and tax laws) that have been enacted or substantively enacted at the reporting date.

Deferred tax assets and deferred tax liabilities are offset if a legally enforceable right exists to set off current tax assets against current tax liabilities and the deferred taxes relate to the same taxable entity and the same taxation authority.

Deferred tax relating to items recognised outside profit or loss is recognised outside profit or loss. Deferred tax items are recognised in correlation to the underlying transaction either in OCI or directly in equity.

2.17 Financial instruments

Financial assets and liabilities are recognised when the company becomes a party to the contractual provisions of the instrument. Financial assets and liabilities are initially measured at fair value. Transaction costs that are directly attributable to the acquisition or issue of financial assets and financial liabilities (other than financial assets and financial liabilities at fair value through profit or loss) are added to or deducted from the fair value measured on initial recognition of financial asset or financial liability.

The Company derecognises a financial asset only when the contractual rights to the cash flows from the asset expire, or when it transfers the financial asset and substantially all the risks

and rewards of ownership of the asset to another entity. The Company derecognises financial liabilities when, and only when, the Company's obligations are discharged, cancelled or have expired.

Cash and cash equivalents

The Company considers all highly liquid financial instruments, which are readily convertible into known amounts of cash that are subject to an insignificant risk of change in value and having original maturities of three months or less from the date of purchase, to be cash equivalents. Cash and cash equivalents consist of balances with banks which are unrestricted for withdrawal and usage.

Financial assets at amortised cost

Financial assets are subsequently measured at amortised cost if these financial assets are held within a business whose objective is to hold these assets in order to collect contractual cash flows and the contractual terms of the financial asset give rise on specified dates to cash flows that are solely payments of principal and interest on the principal amount outstanding.

Financial assets at fair value through other comprehensive income

Financial assets are measured at fair value through other comprehensive income if these financial assets are held within a business whose objective is achieved by both collecting contractual cash flows on specified dates that are solely payments of principal and interest on the principal amount outstanding and selling financial assets.

Financial assets at fair value through profit or loss

Financial assets are measured at fair value through profit or loss unless they are measured at amortised cost or at fair value through other comprehensive income on initial recognition. The transaction costs directly attributable to the acquisition of financial assets and liabilities at fair value through profit or loss are immediately recognised in statement of profit and loss.

Financial liabilities

Financial liabilities are measured at amortised cost using the effective interest method.

Equity instruments

An equity instrument is a contract that evidences residual interest in the assets of the company after deducting all of its liabilities. Equity instruments issued by the Company are recognised at the proceeds received net of direct issue cost.

Offsetting of financial instruments

Financial assets and financial liabilities are offset

and the net amount is reported in the balance sheet if there is a currently enforceable legal right to offset the recognised amounts and there is an intention to settle on a net basis, to realise the assets and settle the liabilities simultaneously.

Impairment of financial assets

The company applies expected credit loss (ECL) model for measurement and recognition of impairment loss on the assets carried at amortised cost and FVTOCI debt instruments. The impairment methodology applied depends on whether there has been a significant increase in credit risk. Note 35 details how the company determines whether there has been a significant increase in credit risk.

For trade receivables only, the company applies the simplified approach permitted by 'Ind AS 109 - Financial instruments', which requires expected lifetime losses to be recognised from initial recognition of the receivables.

2.18 Fair value measurement

For the purpose of fair value disclosures, the Company has determined classes of assets and liabilities based on the nature, characteristics and risks of the asset or liability and the level of the fair value hierarchy as;

Level 1 - Quoted (unadjusted) market prices in active markets for identical assets or liabilities.

Level 2 - Valuation techniques for which the lowest level input that is significant to the fair value measurement is directly or indirectly observable.

Level 3 - Valuation techniques for which the lowest level input that is significant to the fair value measurement is unobservable.

The company uses valuation techniques that are appropriate in the circumstances and for which sufficient data is available to measure fair value, maximizing the use of relevant observable inputs and minimizing the use of unobservable inputs.

2.19 Provisions and contingencies

A provision is recognised when the company has a present obligation as a result of past event and it is probable that an outflow of resources will be required to settle the obligation, in respect of which a reliable estimate can be made. These are reviewed at each balance sheet date and adjusted to reflect the current best estimates.

Contingent liabilities are disclosed when there is a possible obligation arising from past events, the existence of which will be confirmed only by the occurrence or non-occurrence of one or more uncertain future events not wholly within

the control of the Company or a present obligation that arises from past events where it is either not probable that an outflow of resources will be required to settle the obligation or a reliable estimate of the amount cannot be made. Contingent assets are neither recognised nor disclosed in the financial statements.

2.20 Earnings per share (EPS)

Basic earnings per share is computed by dividing profit or loss attributable to equity shareholders of the Company by the weighted average number of equity shares outstanding during the year. The Company did not have any potentially dilutive securities in any of the years presented.

2.21 Cash dividend to equity holders

The company recognises a liability to make cash distributions to equity holders when the distribution is authorised and the distribution is no longer at the discretion of the company. As per the corporate laws in India, a distribution is authorised when it is approved by the shareholders. A corresponding amount is recognised directly in equity.

2.22 Government grant

Government grants are recognised at their fair value when there is a reasonable assurance that the grant will be received and company will comply with all attached conditions.

Government grants relating to income are deferred and recognised in the statement of profit and loss over the period necessary to match them with costs that they are intended to compensate and presented within other income.

Government grants relating to purchase of property, plant and equipment are initially recognised as deferred income at fair value and subsequently recognised in the statement of profit and loss on a systematic basis over the useful life of the asset.

2.23 Recent accounting pronouncements

Ministry of Corporate Affairs ("MCA") through Companies (Indian Accounting Standards) Amendment Rules, 2019 and Companies (Indian Accounting Standards) Second Amendment Rules, has notified the following new and amendments to Ind AS which the Company has not applied as they are effective from April 1, 2019:

Ind AS 116 – Leases

Ind AS 116 will replace the existing leases standard, Ind AS 17 Leases. Ind AS 116 sets out the principles for the recognition, measurement, presentation and disclosure of leases for both lessees and lessor. It introduces a single, on-balance sheet lessee accounting model for lessees. A lessee recognises right-of-use asset representing its right to use the underlying asset and a lease liability representing its obligation to make lease payments. The standard also contains enhanced disclosure requirements for lessees. Ind AS 116 substantially carries forward the lessor accounting requirements in Ind AS 17. The Company will adopt Ind AS 116 effective annual reporting period beginning April 1, 2019.

Ind AS 23 – Borrowing Costs

The amendments clarify that if any specific borrowing remains outstanding after the related asset is ready for its intended use or sale, that borrowing becomes part of the funds that an entity borrows generally when calculating the capitalisation rate on general borrowings. The Company does not expect any impact from this amendment.

Ind AS 28 – Long-term Interests in Associates and Joint Ventures

The amendments clarify that an entity applies Ind AS 109 Financial Instruments, to long-term interests in an associate or joint venture that form part of the net investment in the associate or joint venture but to which the equity method is not applied. The Company does not currently have any long-term interests in associates and joint ventures.

Ind AS 103 – Business Combinations and Ind AS 111 – Joint Arrangement

The amendments to Ind AS 103 relating to re-measurement clarify that when an entity obtains control of a business that is a joint operation, it re-measures previously held interests in that business. The amendments to Ind AS 111 clarify that when an entity obtains joint control of a business that is a joint operation, the entity does not remeasure previously held interests in that business. The Company does not currently have any control of a business that is a joint operation.

Notes to financial statements for the year ended 31st March, 2020
Note-3 :Property Plant and Equipment and Intangible Assets

(INR in Lakhs)

| | Lease-hold Land ** | Free-hold Land | Buildings | Plant & Machinery | Electrical Installation & Fittings | Dies, Jigs & Fixtures | Furniture Fixture | Office Equipment | Vehicles | Total | Technical Know-how ** |
|--|--------------------|----------------|-----------|-------------------|------------------------------------|-----------------------|-------------------|------------------|----------|-----------|-----------------------|
| (A) Gross carrying amount | | | | | | | | | | | |
| Balance as at 1st April 2018 | 94.60 | 2,080.00 | 3,087.72 | 17,655.51 | 205.88 | 6,545.58 | 405.67 | 567.32 | 63.34 | 30,705.63 | 609.82 |
| Additions | - | - | - | 101.97 | 1.76 | 130.82 | 16.40 | 6.20 | - | 257.15 | 4.07 |
| Disposals | - | - | - | (141.45) | - | - | - | - | - | (141.45) | - |
| Balance as at 31 March 2019 | 94.60 | 2,080.00 | 3,087.72 | 17,616.03 | 207.64 | 6,676.40 | 422.07 | 573.52 | 63.34 | 30,821.33 | 613.89 |
| Additions | - | - | - | 67.61 | - | 92.00 | 2.86 | 15.98 | 0.07 | 178.52 | - |
| Disposals | - | - | - | - | - | - | - | - | - | - | - |
| Balance as at 31 March 2020 | 94.60 | 2,080.00 | 3,087.72 | 17,683.64 | 207.64 | 6,768.40 | 424.93 | 589.50 | 63.41 | 30,999.84 | 613.89 |
| (B) Depreciation and impairment | | | | | | | | | | | |
| Balance as at 1st April 2018 | 22.49 | - | 2,934.00 | 12,116.07 | 183.78 | 5,717.38 | 359.91 | 548.59 | 52.70 | 21,934.92 | 601.10 |
| Depreciation for the year | 0.96 | - | 22.84 | 578.89 | 6.33 | 103.24 | 6.05 | 7.57 | 4.01 | 729.89 | 4.52 |
| Deductions | - | - | - | (137.63) | - | - | - | - | - | (137.63) | - |
| Balance as at 31 March 2019 | 23.45 | - | 2,956.84 | 12,557.33 | 190.11 | 5,820.62 | 365.96 | 556.16 | 56.71 | 22,527.18 | 605.62 |
| Depreciation for the year | 0.96 | - | 17.72 | 567.79 | 5.53 | 106.93 | 5.55 | 8.50 | 3.10 | 716.10 | 5.16 |
| Deductions | - | - | - | - | - | - | - | - | - | - | - |
| Balance as at 31 March 2020 | 24.41 | - | 2,974.56 | 13,125.12 | 195.64 | 5,927.55 | 371.51 | 564.66 | 59.81 | 23,243.28 | 610.78 |
| (C) Written Down Value | | | | | | | | | | | |
| Balance as at 31 March 2020 | 70.19 | 2,080.00 | 113.16 | 4,558.52 | 12.00 | 840.85 | 53.41 | 24.84 | 3.59 | 7,756.57 | 3.11 |
| Balance as at 31 March 2019 | 71.15 | 2,080.00 | 130.88 | 5,058.70 | 17.53 | 855.78 | 56.11 | 17.36 | 6.63 | 8,294.15 | 8.27 |

** Amortisation Charges For the year are in Respect of Leasehold Land And Technical Know-how.

NOTE :
Gross block includes revaluation of assets made in terms of Arrangement approved by 'Bombay High court as under

- a) Free Hold Land
- c) Building
- d) Lease hold land

Notes to financial statements for the year ended 31st March, 2020
Note 4: Investments
4 (a) Non-current investments

(INR in Lakhs)

| PARTICULARS | 31st March, 2020 | 31st March, 2019 |
|---|-------------------------|-------------------------|
| Investment in Equity instruments (fully paid-up) | | |
| Equity instruments at FVTPL | | |
| Unquoted | | |
| Kinetic Communications Limited | 10.22 | 8.21 |
| Kinetic Escalator and Elevator Limited | 40.24 | 30.74 |
| Kinetic Marketing & Services Limited | - | - |
| Kinetic Motor Automotives Private Limited | - | 0.91 |
| Total (equity instruments) | 50.46 | 39.87 |
| Investment in preference shares (fully paid-up) | | |
| Preference instruments at FVTPL | | |
| Unquoted | | |
| Kinetic Green Energy and Power Solutions Ltd. [4,71,000 (31 March 2019: 5,90,000) Preference shares of Rs 100 each fully paid up] | 471.00 | 590.00 |
| Total (preference shares) | 471.00 | 590.00 |
| Investment in Shares (classified as FVTPL) | | |
| Daewoo Motors (India) Limited (Formerly DCM Toyota Ltd.) | 0.01 | 0.01 |
| Eicher Limited | 0.03 | 0.03 |
| Escorts Limited | 0.33 | 0.40 |
| Hindustan Motors Limited | 0.01 | 0.01 |
| LML Limited | 0.00 | 0.00 |
| Majestic Auto Limited | 0.06 | 0.13 |
| Hero Motocorp Limited (Formerly Hero Motors Limited) | 0.02 | 0.03 |
| The Premier Automobiles Limited | 0.00 | 0.00 |
| Saraswat Co-operative Bank Limited | 0.25 | 0.25 |
| Ajinkya Auto Fab Limited | 19.93 | 18.64 |
| Total (Shares) | 20.64 | 19.51 |
| Investment in Government Securities (classified as FVTPL) | | |
| 7 Years National Savings Certificates | 0.24 | 0.24 |
| Total (Investment in Securities) | 0.24 | 0.24 |
| Total Non-current investments | 542.20 | 649.62 |

4(b) Current investments

| PARTICULARS | 31st March, 2020 | 31st March, 2019 |
|--|-------------------------|-------------------------|
| Investment in Mutual Fund (classified as FVTPL) | | |
| HDFC Cash Management Fund | - | - |
| BIRLA Sunlife Saving Fund | 0.11 | 0.11 |
| Total current investments | 0.11 | 0.11 |

Notes to financial statements for the year ended 31st March, 2020
Note - 5 : Other Non Current Financial Asset
(INR in Lakhs)

| PARTICULARS | 31st March 2020 | 31st March 2019 |
|---|------------------------|------------------------|
| (a) Security Deposits | | |
| Unsecured, considered good | 151.92 | 151.86 |
| Doubtful | 13.02 | 13.02 |
| | 164.94 | 164.88 |
| Less: Provision for doubtful deposits | 13.02 | 13.02 |
| | 151.92 | 151.86 |
| (b) Other Loans and advances | | |
| (i) Advances | | |
| Unsecured, considered good | 95.99 | 95.99 |
| Doubtful | 9.13 | 9.13 |
| | 105.12 | 105.12 |
| Less: Provision for doubtful advances | 9.13 | 9.13 |
| | 95.99 | 95.99 |
| (ii) Bills Receivable (Refer Note-40 for details) | 206.65 | 206.65 |
| Total | 454.57 | 454.51 |

Note - 6: Deferred tax assets (Net)
(INR in Lakhs)

| PARTICULARS | 31st March 2020 | 31st March 2019 |
|---|------------------------|------------------------|
| Deferred tax liability | | |
| (i) On accumulated depreciation | 505.74 | 695.39 |
| (ii) On other timing differences | - | - |
| Deferred tax liability (A) | 505.74 | 695.39 |
| Deferred tax assets | | |
| (i) On disallowance under Section 43B & 40A of Income Tax Act, 1961 | 359.57 | 341.63 |
| (ii) On provision for doubtful debts | 5.16 | 5.16 |
| (iii) On carried forward loss under Income Tax Act, 1961 | 141.01 | 348.60 |
| Deferred tax assets (B) | 505.74 | 695.39 |

Note - 7: Other Non Current Assets
(INR in Lakhs)

| PARTICULARS | 31st March 2020 | 31st March 2019 |
|---------------------------------------|------------------------|------------------------|
| (a) Capital Advances | | |
| Unsecured, considered good | 61.03 | 63.98 |
| Doubtful | - | - |
| | 61.03 | 63.98 |
| Less: Provision for doubtful advances | - | - |
| | 61.03 | 63.98 |
| (b) Others | - | - |
| Total | 61.03 | 63.98 |

Note - 8: Inventories
(INR in Lakhs)

| PARTICULARS | 31st March 2020 | 31st March 2019 |
|------------------------|------------------------|------------------------|
| (i) Raw Materials | 611.84 | 694.65 |
| (ii) Work-in-progress | 1,477.07 | 1,601.30 |
| (iii) Finished goods | 5.48 | 5.48 |
| (iv) Stores and spares | 883.43 | 805.82 |
| Total | 2,977.81 | 3,107.25 |

Notes to financial statements for the year ended 31st March, 2020
Note - 9: Trade Receivables
(INR in Lakhs)

| PARTICULARS | 31st March 2020 | 31st March 2019 |
|-------------------------------------|------------------------|------------------------|
| (i) Unsecured, considered good | 2,364.94 | 2,858.97 |
| (ii) Unsecured, considered doubtful | - | - |
| | 2,364.94 | 2,858.97 |
| Less: Allowance for doubtful debts | - | - |
| Total | 2,364.94 | 2,858.97 |

No trade receivables are due from directors or other officers of the company either severally or jointly with any other person, nor any trade receivables are due from firms or private companies respectively in which and director is a partner or a member. Trade Receivables are non-interest bearing and generally on credit terms of 60 to 90 days.

Note - 10 : Cash and cash equivalents
(INR in Lakhs)

| PARTICULARS | 31st March 2020 | 31st March 2019 |
|------------------------|------------------------|------------------------|
| (i) Balance with Banks | 72.52 | 33.86 |
| (ii) Cash on hand | 0.14 | 0.17 |
| Total | 72.66 | 34.02 |

Note - 11: Other Bank Balances
(INR in Lakhs)

| PARTICULARS | 31st March 2020 | 31st March 2019 |
|---|------------------------|------------------------|
| (i) Fixed deposits (more than 3 months but less than 12 months) | 11.80 | 11.42 |
| Total | 11.80 | 11.42 |

Note - 12 : Current Loans
(INR in Lakhs)

| PARTICULARS | 31st March 2020 | 31st March 2019 |
|--|------------------------|------------------------|
| (i) Deposits with Govt. authorities | | |
| Unsecured, considered good | 3.65 | 3.65 |
| Doubtful | - | - |
| | 3.65 | 3.65 |
| Less: Provision for doubtful advances | - | - |
| Total | 3.65 | 3.65 |

Note - 13: Other Current Financial Assets
(INR in Lakhs)

| PARTICULARS | 31st March 2020 | 31st March 2019 |
|--|------------------------|------------------------|
| (i) Interest Accrued on Investments & Deposits | 5.20 | 5.04 |
| (ii) Receivable of Sale of Undertaking | - | - |
| Total | 5.20 | 5.04 |

Note - 14 : Current Tax Assets(Net)
(INR in Lakhs)

| PARTICULARS | 31st March 2020 | 31st March 2019 |
|---|------------------------|------------------------|
| (i) Advance Income tax net of provision | 151.22 | 139.07 |
| Total | 151.22 | 139.07 |

Notes to financial statements for the year ended 31st March, 2020
Note - 15: Other current assets
(INR in Lakhs)

| PARTICULARS | 31st March 2020 | 31st March 2019 |
|---------------------------------------|------------------------|------------------------|
| (i) Advances to suppliers and others | | |
| Unsecured, considered good | 382.33 | 475.74 |
| Doubtful | - | - |
| | 382.33 | 475.74 |
| Less: Provision for doubtful advances | - | - |
| Total | 382.33 | 475.74 |

Note-16: Share Capital
A. Authorised Share Capital
(i) Equity Share Capital
(INR in Lakhs)

| PARTICULARS | Equity Share | |
|---|---------------------|-----------------|
| | Number | Rs. |
| Authorised shares as at April 01, 2018 | 53,013,932 | 5,301.39 |
| Increase/(decrease) during the year | - | - |
| Total shares authorised as at March 31, 2019 | 53,013,932 | 5,301.39 |
| Increase/(decrease) during the year | - | - |
| Total authorised Equity share capital as at March 31, 2020 | 53,013,932 | 5,301.39 |

(ii) Preference Share Capital
(INR in Lakhs)

| PARTICULARS | Preference Share | |
|--|-------------------------|------------------|
| | Number | Rs. |
| Authorised shares as at April 01, 2018 | 42,223,780 | 14,289.43 |
| Increase/(decrease) during the year | - | - |
| Total shares authorised as at March 31, 2019 | 42,223,780 | 14,289.43 |
| Increase/(decrease) during the year | - | - |
| Total authorised Preference share capital as at 31 March 2020 | 42,223,780 | 14,289.43 |
| Total authorised Share Capital as at March 31 2020 | 95,237,712 | 19,590.83 |

B. Issued, Subscribed & fully Paid Up Share Capital
(i) Equity Share Capital
(INR in Lakhs)

| PARTICULARS | Equity Share | |
|------------------------------------|---------------------|-----------------|
| | Number | Rs. |
| Balance as at April 01, 2018 | 17,708,621 | 1,770.86 |
| Changes during the period | - | - |
| Balance as at March 31 2019 | 17,708,621 | 1,770.86 |
| Changes during the period | - | - |
| Balance as at March 31 2020 | 17,708,621 | 1,770.86 |

Notes to financial statements for the year ended 31st March, 2020
C. Details of equity shareholders holding more than 5% shares

(INR in Lakhs)

| Name of shareholder | 31st March 2020 | | 31st March 2019 | |
|------------------------------------|-----------------|--------------|-----------------|--------------|
| | No. of Shares | % of Holding | No. of Shares | % of Holding |
| Jayashree A. Firodia | 3,475,222 | 19.62% | 3,475,222 | 19.62% |
| Microage Instruments pvt ltd. | 3,953,683 | 22.33% | 3,953,683 | 22.33% |
| Ashoka Investment Holdings Limited | 1,750,452 | 9.88% | 1,787,294 | 10.09% |
| Ajinkya Arun Firodia | 1,129,055 | 6.38% | 1,129,055 | 6.38% |

D. Terms/rights attached to equity shares

- The company has only one class of equity shares, having par value of Rs. 10 per share. Each holder of equity share is entitled for one vote per share and has a right to receive dividend, as recommended by the board of directors subject to the necessary approval from the shareholders. In the event of liquidation of the company, the holders of equity shares will be entitled to receive remaining assets of the company after distribution of all preferential amounts. The distribution will be in proportion to the number of equity shares held by the shareholders.
- Out of above, 18,85,450 (18,85,450) Equity Shares were allotted as fully paid up Bonus Shares on Capitalisation of the General Reserve.
- Out of above, 36,700 (36,700) Equity Shares were allotted under Employee Stock Option Scheme.
- In respect of 8,24,359 Equity Shares allotted on Preferential basis and 9,77,913 shares allotted on conversion, the company is in the process of obtaining necessary approval from BSE/SEBI.

Note 17: Other Equity

(INR in Lakhs)

| PARTICULARS | 31st March 2020 | 31st March 2019 |
|---|--------------------|--------------------|
| A. PREFERENCE SHARE CAPITAL | | |
| a) 1,02,000 Optionally Convertible Cumulative Preference Shares of Rs. 156/- each (Note no.17 H-1) | 159.12 | 159.12 |
| b) 3,20,500 Redeemable Cumulative Preference Shares of Rs. 156/- each.(Note no.17 H-2) | 499.98 | 499.98 |
| c) 8,30,154 Optionally Convertible Cumulative Preference Shares of Rs. 65/- each (Note no.17 H-3) | 539.60 | 539.60 |
| d) 11,76,650 8.5% New Optionally Convertible Cumulative Preference Shares of Rs. 65/- each (Note no.18 H-4) | 764.82 | 764.82 |
| Total | 1,963.52 | 1,963.52 |
| B. Capital Reserves | | |
| Opening Balance | 3,535.19 | 3,535.19 |
| (+)/(-) Transfer | - | - |
| Closing Balance | 3,535.19 | 3,535.19 |
| C. Securities Premium Account | | |
| Opening Balance | 9,384.06 | 9,384.06 |
| (+)/(-) Transfer | - | - |
| Closing Balance | 9,384.06 | 9,384.06 |
| D. General Reserve | | |
| Opening balance | 8,669.25 | 8,669.25 |
| (+)/(-) Transfer | - | - |
| Closing Balance | 8,669.25 | 8,669.25 |
| E. Special Reserve | | |
| Opening balance | 0.46 | 0.46 |
| (+)/(-) Transfer | - | - |
| Closing Balance | 0.46 | 0.46 |
| F. Surplus | | |
| Opening balance | (22,998.89) | (22,116.77) |
| Other Comprehensive Income | (30.71) | (64.83) |
| (+) Net Profit / (Net Loss) for the current year | (911.74) | (816.37) |
| (+) Fair Value revaluation balance of Investment sold | - | (0.92) |
| Closing Balance | (23,941.33) | (22,998.89) |
| Total (A+B+C+D+E+F) | (388.86) | 553.58 |

Notes to financial statements for the year ended 31st March, 2020
G. Details of Preference shareholders holding more than 5% shares
(INR in Lakhs)

| Name of shareholder | 31st March 2020 | | 31st March 2019 | |
|---|-----------------|--------------|-----------------|--------------|
| | No. of Shares | % of Holding | No. of Shares | % of Holding |
| Optionally Convertible Cumulative Preference Share Capital: | | | | |
| (a) Microage Instruments Private Limited | 102,000 | 100.00% | 102,000 | 100.00% |
| (b) Microage Instruments Private Limited | 830,154 | 100.00% | 830,154 | 100.00% |
| Redeemable Cumulative Preference Share Capital: | | | | |
| (a) Microage Instruments Private Limited | 320,500 | 100.00% | 320,500 | 100.00% |
| 8.5% New Optionally Convertible Cumulative Preference Share Capital: | | | | |
| (a) Microage Instruments Private Limited | 1,176,650 | 100.00% | 1,176,650 | 100.00% |

H. Terms/rights attached to Preference shares

- Each Optionally Convertible Cumulative Preference Share (OCCPS) is convertible into one fully paid up equity share of the face value of Rs. 10/- each at a premium of Rs. 146/- per share within 18 months from the date of allotment (i.e. 30.12.2006 wrt. 36,923 shares; and 11.1.2007 wrt. 65,077 shares) at the option of the allottee. The OCCPS shall carry a preferential right to be paid a fixed rate of dividend @ 1% p.a. due and payable on the date of their conversion into equity shares or such other date(s) as may be acceptable to allottee. If any OCCPS is not converted into equity shares, such unconverted preference shares shall carry preferential right to be paid a fixed rate of dividend @ 8.50% p.a. due and payable on the date of their redemption or such other date(s) as may be acceptable to the allottee and will be redeemed any time after expiry of a period of 5 years from the date of allotment at the option of the Company subject to necessary consent and approval. The option to convert has lapsed.
- Redeemable Cumulative Preference Shares shall be redeemed at the option of the Company at any time after the expiry of a period of 5 years from the date of allotment i.e. 30.12.2006, subject to necessary consent or approval. They will carry a preferential right to be paid a fixed rate of dividend @ 8.50% p.a. due and payable on the date of their redemption or other date(s) as may be acceptable to the allottee.
- Each Optionally convertible cumulative preference shares (OCCPS) is convertible into one fully paid up equity share of the face value of Rs.10/- each at a premium of Rs.55/- per share within a period of 18 months from the date of allotment (i.e. 18.09.2013) at the option of the allottee. The OCCPS shall carry a preferential right to be paid a fixed rate of dividend at 1% p.a. due and payable on the date of their conversion into equity shares or such other date(s) as may be acceptable to the allottee. If any OCCPS are not converted into equity shares, such unconverted preference shares shall carry preferential rights to be paid a fixed rate of dividend at 8.5% p.a. due and payable on the date of their redemption or such other date(s) as may be acceptable to the allottees and will be redeemed any time after the expiry of a period of 18 months from the date of allotment at the option of the allottee. The Option to convert has lapsed.
- Each 8.5% new Optionally convertible cumulative preference shares (OCCPS) is convertible into one fully paid up equity share of the face value of Rs. 10/- each at a premium of Rs.55/- per share within a period of 18 months from the date of allotment (i.e. 18.09.2013) at the option of the allottee. The 8.5% new OCCPS shall carry a preferential right to be paid a fixed rate of dividend at 1% p.a. due and payable on the date of their conversion into equity shares or such other date(s) as may be acceptable to allottees. If any 8.5% new OCCPS are not converted into equity shares such unconverted preference shares shall carry preferential rights to be paid a fixed rate of dividend at 8.5% pa due and payable on the date of their redemption or such other date(s) as may be acceptable to the allottees and will be redeemed any time after expiry of a period of 18 months from the date of allotment at the option of the allottee. The Option to convert has lapsed.
- On 5th February, 2018, the Company, on request of allottees, has exercised its option for conversion of 9,92,639 (8.5% Optionally Convertible Cumulative Preference shares of Rs. 22/- each with premium of Rs. 67.66 /- each) into equity shares of Rs.10/- with premium of Rs. 81.01 each, ranking pari passu with the existing equity shares of the Company. The company is in the process of obtaining necessary approval from BSE/SEBI in respect of preferential allotment made.
- Classification of Preference Shares.-Preference shareholders have given their "in-principal consent" for waiver of cumulative fixed dividend on their preference shares and for converting them into equity shares as per the applicable laws. In view of the above, no provision for dividend under finance cost has been considered necessary & it is considered as other equity.

Notes to financial statements for the year ended 31st March, 2020
Note - 18: Non Current Borrowings

(INR in Lakhs)

| PARTICULARS | 31st March 2020 | 31st March 2019 |
|---|------------------------|------------------------|
| Secured | | |
| (a) Term Loans from Banks | 766.66 | 851.89 |
| Unsecured | | |
| (a) Loans and advances from related parties | 2,271.89 | 2,119.90 |
| (b) Term Loans from Others | 415.38 | 506.94 |
| Total | 3,453.93 | 3,478.72 |

Note -19: Non Current Provisions

(INR in Lakhs)

| PARTICULARS | 31st March 2020 | 31st March 2019 |
|--|------------------------|------------------------|
| Provision for employee benefits : | | |
| (a) Gratuity | 429.27 | 471.07 |
| (b) Leave Encashment | 61.47 | 66.93 |
| Total | 490.74 | 538.00 |

Note -20: Other Non Current Liabilities

(INR in Lakhs)

| PARTICULARS | 31st March 2020 | 31st March 2019 |
|--|------------------------|------------------------|
| (a) Others | | |
| (i) Remeasurement of Long Term Liabilities | 1,061.00 | 1,281.09 |
| | 1,061.00 | 1,281.09 |

Note - 21: Current Borrowings

(INR in Lakhs)

| PARTICULARS | 31st March 2020 | 31st March 2019 |
|-------------------------------------|------------------------|------------------------|
| Secured | | |
| (a) Cash Credit Facility from Banks | 989.76 | 993.77 |
| Unsecured | | |
| (a) Overdraft Facility from Banks | 1,475.20 | 1,339.59 |
| Total | 2,464.97 | 2,333.37 |

Cash credit from banks are repayable on demand and are secured by hypothecation of Stock and Debtors (excluding Tata Motors Ltd.) and pari-passu second charge on factory land and building at Ahmednagar.

Note - 22: Trade payables

(INR in Lakhs)

| PARTICULARS | 31st March 2020 | 31st March 2019 |
|--------------------|------------------------|------------------------|
| Unsecured : | | |
| (a) Trade payables | 4,046.43 | 4,379.80 |
| Total | 4,046.43 | 4,379.80 |

Note - 23: Other Current Financial Liabilities

(INR in Lakhs)

| PARTICULARS | 31st March 2020 | 31st March 2019 |
|---|------------------------|------------------------|
| (a) Current maturities of long-term debt | 236.72 | 225.38 |
| (b) Interest accrued and due on borrowings | 124.09 | 124.09 |
| (c) Interest accrued but not due on borrowings | 17.37 | 17.95 |
| (d) Other payables | | |
| (i) Premium payable on Redemption of Debentures | 35.20 | 49.20 |
| (ii) Capital Creditors | 26.50 | 38.59 |
| (iii) Other Liabilities | 510.09 | 548.11 |
| Total | 949.97 | 1,003.32 |

Notes to financial statements for the year ended 31st March, 2020
Note - 24: Other Current Liabilities

(INR in Lakhs)

| PARTICULARS | 31st March 2020 | 31st March 2019 |
|---|------------------------|------------------------|
| (a) Other payables | | |
| (i) Advance against Sales | 65.35 | 6.91 |
| (ii) Remeasurement of current maturities of Long Term Liabilities | 197.14 | 192.15 |
| (iii) Other Liabilities | 137.51 | 128.35 |
| Total | 400.00 | 327.39 |

Note - 25 : Current Provisions

(INR in Lakhs)

| PARTICULARS | 31st March 2020 | 31st March 2019 |
|--|------------------------|------------------------|
| Provision for employee benefits : | | |
| (a) Gratuity | 513.10 | 416.07 |
| (b) Leave Encashment | 25.14 | 23.58 |
| Total | 538.24 | 439.65 |

25.1 Employee benefits
a) Defined contribution plans
(i) Provident fund

The Company operates plan for its employees to provide employee benefits in the nature of "Provident fund" and "Employee Pension Schemes". Contributions are made at the rate as prescribed in the regulations. The Company has recognised following amount in the statement of profit and loss:

| Particulars | 31st March 2020 | 31st March 2019 |
|--------------------------|------------------------|------------------------|
| Provident fund | 53.51 | 46.89 |
| Employees Pension Scheme | 88.32 | 81.34 |
| Total | 141.82 | 128.23 |

b) Defined benefit plan
(i) Gratuity

In accordance with the Payment of Gratuity Act, 1972, the Company is required to provide post-employment benefit to its employees in the form of gratuity. The Company has maintained a fund with Reliance Nippon Life Insurance Company Limited of India, to meet its gratuity obligations. In accordance with the Standard, the disclosures relating to the Company's gratuity plan are provided below:

(INR in Lakhs)

| Particulars | 31st March 2020 | 31st March 2019 |
|--------------------|------------------------|------------------------|
| Gratuity | | |
| Non-current | 429.27 | 471.07 |
| Current | 513.10 | 416.07 |
| Total | 942.38 | 887.15 |

The changes in the present value of defined benefit obligation representing reconciliation of opening and closing balances thereof are as follows: (INR in Lakhs)

| Particulars | 31st March 2020 | 31st March 2019 |
|--|------------------------|------------------------|
| Present value of obligation as at the beginning of the period | 886.07 | 794.97 |
| Transfer In/(Out) | 0.11 | |
| Interest cost | 66.22 | 59.59 |
| Current service cost | 26.98 | 24.92 |
| Benefits paid | (52.24) | (61.88) |
| Remeasurements on obligation - (gain) / loss | 30.00 | 68.47 |
| Present value of obligation as at the end of the period | 957.15 | 886.07 |

Notes to financial statements for the year ended 31st March, 2020

The changes in the fair value of planned assets representing reconciliation of opening and closing balances thereof are as follows:

(INR in Lakhs)

| Particulars | 31st March 2020 | 31st March 2019 |
|---|-----------------|-----------------|
| Fair value of plan assets at the beginning of the period | 23.68 | 20.52 |
| Interest income | 2.17 | 1.56 |
| Contributions | 56.60 | 58.05 |
| Benefits paid | (47.53) | (59.11) |
| Monthly charges and Taxes | (0.83) | (0.98) |
| Transfer In / (Out) | - | - |
| Return on plan assets, excluding amount recognized in interest income - gain / (loss) | (0.71) | 3.64 |
| Fair value of plan assets as at the end of the period | 33.39 | 23.68 |

Amounts recognised in the balance sheet are as follows:

(INR in Lakhs)

| Particulars | 31st March 2020 | 31st March 2019 |
|---|-----------------|-----------------|
| Present value of obligation as at the end of the period | 957.15 | 886.07 |
| Fair value of plan assets as at the end of the period | 33.39 | 23.68 |
| Surplus / (deficit) | (923.76) | (862.39) |

Amounts recognised in the statement of profit and loss are as follows:

(INR in Lakhs)

| Particulars | 31st March 2020 | 31st March 2019 |
|---|-----------------|-----------------|
| Current service cost | 26.98 | 24.92 |
| Net interest (income) / expense | 64.05 | 58.04 |
| Transfer In/ (Out) | 0.11 | |
| Net periodic benefit cost recognised in the statement of profit and loss | 91.14 | 82.95 |

Amounts recognised in the statement of other comprehensive income (OCI) are as follows:

(INR in Lakhs)

| Particulars | 31st March 2020 | 31st March 2019 |
|--|-----------------|-----------------|
| Remeasurement for the year - obligation (gain) / loss | 30.00 | 68.47 |
| Remeasurement for the year - plan assets (gain) / loss | 0.71 | (3.64) |
| Total remeasurements cost / (credit) for the year | 30.71 | 64.83 |

Net interest (income) / expense recognised in statement of profit and loss are as follows:

(INR in Lakhs)

| Particulars | 31st March 2020 | 31st March 2019 |
|---|-----------------|-----------------|
| Interest (income) / expense - obligation | 66.22 | 59.59 |
| Interest (income) / expense - plan assets | (2.17) | (1.56) |
| Net interest (income) / expense for the year | 64.05 | 58.03 |

Notes to financial statements for the year ended 31st March, 2020

Principal actuarial assumptions used in determining gratuity benefit obligations for the Company's plans are as follows:

| Particulars | 31st March 2020 | 31st March 2019 |
|--|------------------------|------------------------|
| Discount rate | 6.80% | 7.70% |
| Rate of increase in compensation levels | 3.00% | 3.00% |
| Expected rate of return on plan assets | 7.70% | 7.80% |
| Expected average remaining working lives of employees (in years) | 11.73* | 11.87* |
| Withdrawal rate | | |
| Age upto 30 years | 1.00% | 1.00% |
| Age 31 - 40 years | 1.00% | 1.00% |
| Age 41 - 50 years | 1.00% | 1.00% |
| Age above 50 years | 1.00% | 1.00% |

* It is actuarially calculated term of the liability using probabilities of death, withdrawal and retirement

A quantitative sensitivity analysis for significant assumptions are shown as follows:

Sensitivity analysis indicates the influence of a reasonable change in certain significant assumptions on the outcome of the present value of obligation (PVO) and aids in understanding the uncertainty of reported amounts. Sensitivity analysis is done by varying (increasing/ decreasing) one parameter by 100 basis points (1%) at a time:

a) Impact of change in discount rate when base assumption is decreased / increased by 100 basis point
(INR in Lakhs)

| Discount rate | Present value of obligation | |
|----------------------|------------------------------------|------------------------|
| | 31st March 2020 | 31st March 2019 |
| Decrease by 1% | 981.62 | 910.75 |
| Increase by 1% | 934.90 | 863.46 |

b) Impact of change in salary increase rate when base assumption is decreased / increased by 100 basis point
(INR in Lakhs)

| Salary increment rate | Present value of obligation | |
|------------------------------|------------------------------------|------------------------|
| | 31st March 2020 | 31st March 2019 |
| Decrease by 1% | 939.42 | 867.84 |
| Increase by 1% | 976.44 | 905.71 |

c) Impact of change in withdrawal rate when base assumption is decreased / increased by 100 basis point
(INR in Lakhs)

| Withdrawal rate | Present value of obligation | |
|------------------------|------------------------------------|------------------------|
| | 31st March 2020 | 31st March 2019 |
| Decrease by 1% | 952.31 | 880.38 |
| Increase by 1% | 961.54 | 891.28 |

Notes to financial statements for the year ended 31st March, 2020
Note - 26: Revenue from operations

(INR in Lakhs)

| PARTICULARS | 31st March 2020 | 31st March 2019 |
|---------------------------------------|------------------------|------------------------|
| (a) Sale of Products | 11,071.99 | 11,221.94 |
| (b) Machining and Processing Receipts | 196.05 | 226.51 |
| (c) Other operating revenue | 306.67 | 128.90 |
| Total | 11,574.70 | 11,577.35 |

Note - 27: Other income

(INR in Lakhs)

| PARTICULARS | 31st March 2020 | 31st March 2019 |
|---|------------------------|------------------------|
| (a) Interest Income | | |
| (i) On Fixed Deposits | 0.17 | 0.14 |
| (ii) From Others | 6.28 | 14.55 |
| (b) Dividend Income from | | |
| (i) Long Term Investment | 3.97 | 3.65 |
| (ii) Short Term Investment | - | - |
| (c) Profit / (Loss) on sale of Assets | - | 121.46 |
| (d) Profit / (Loss) on sale of Investments | - | - |
| (e) Sundry Credit Balances Written Back | - | 66.11 |
| (f) Excess Provision Written Back | - | 1.26 |
| (g) Amortisation of deferred financial assistance | | |
| (i) From related parties | 181.90 | 183.19 |
| (ii) From others | 33.20 | 33.20 |
| (h) Fair Valuation (Gain)/Loss on Investments | 11.81 | -0.03 |
| (i) Others | 37.82 | 50.58 |
| Total | 275.16 | 474.12 |

Note - 28 : Cost of material consumed

(INR in Lakhs)

| PARTICULARS | 31st March 2020 | 31st March 2019 |
|--|------------------------|------------------------|
| (a) Raw Material Consumed | 4,344.02 | 5,468.41 |
| (b) Stores and Spares Consumed | 1,061.98 | 851.74 |
| (c) Fabrication and Processing Charges | 738.56 | 687.16 |
| (d) Freight, Octroi and Forwarding Charges | 47.69 | 58.48 |
| Total | 6,192.24 | 7,065.78 |

Note - 29: Changes in inventories of finished goods and work-in-progress

(INR in Lakhs)

| PARTICULARS | 31st March 2020 | 31st March 2019 |
|---|------------------------|------------------------|
| Inventory at the end of the year | | |
| (a) Finished Goods | 5.48 | 5.48 |
| (b) Work-In- Progress | 1,477.07 | 1,601.30 |
| Total | 1,482.54 | 1,606.77 |
| Inventory at the beginning of the year | | |
| (a) Finished Goods | 5.48 | 5.48 |
| (b) Work-In- Progress | 1,601.30 | 1,076.96 |
| Total | 1,606.77 | 1,082.43 |
| Increase (-) / decrease (+) in inventories | 124.23 | (524.34) |

Notes to financial statements for the year ended 31st March, 2020
Note - 30: Employee benefit expenses
(INR in Lakhs)

| PARTICULARS | 31st March 2020 | 31st March 2019 |
|--|------------------------|------------------------|
| (a) Salaries & wages | 2,157.53 | 2,213.47 |
| (b) Contributions to provident and other funds | 152.43 | 135.59 |
| (c) Gratuity | 82.90 | 83.43 |
| (d) Staff welfare expenses | 83.59 | 95.78 |
| Total | 2,476.46 | 2,528.27 |

Note - 31: Finance costs
(INR in Lakhs)

| PARTICULARS | 31st March 2020 | 31st March 2019 |
|---------------------------|------------------------|------------------------|
| (a) Interest expense | 450.05 | 388.12 |
| (b) Unwinding of Loans | | |
| (i) Related party loans | 151.99 | 140.49 |
| (ii) Other loans | 40.16 | 44.89 |
| (c) Other Borrowing Costs | 18.19 | 24.73 |
| Total | 660.38 | 598.22 |

Note - 32: Other expenses
(INR in Lakhs)

| PARTICULARS | 31st March 2020 | 31st March 2019 |
|---|------------------------|------------------------|
| (a) Power & Fuel | 1,364.69 | 1,365.88 |
| (b) Repairs and Maintenance: | | |
| (i) Plant and Machinery | 193.79 | 161.27 |
| (ii) Buildings | 40.85 | 37.36 |
| (iii) Others | 2.85 | 2.71 |
| (c) Contract Labour cost | 503.29 | 445.93 |
| (d) Rent | 40.97 | 39.28 |
| (e) Outward Freight Charges | 77.48 | 138.81 |
| (f) Packing and Forwarding Charges | 301.60 | 124.55 |
| (g) Legal, Professional & Consultancy Fee | 86.92 | 104.85 |
| (h) Rates and taxes | 28.24 | 29.20 |
| (i) Travelling Expenses | 18.28 | 28.41 |
| (j) Insurance | 4.69 | 4.55 |
| (k) Payments to auditor (Refer details below) | 4.85 | 4.75 |
| (l) Exchange (Gain) / Loss | (141.84) | (48.93) |
| (m) Excise Duty Paid (Net) | - | - |
| (n) Publicity & Sales Promotion | - | 1.20 |
| (o) Directors Fees & Travelling Expenses | 0.72 | 0.69 |
| (p) Miscellaneous Expenses | 127.76 | 120.63 |
| | 2,655.15 | 2,561.13 |
| Less: Expenses Capitalised | 68.11 | 95.65 |
| Total | 2,587.04 | 2,465.48 |
| Details of payments to Auditors | | |
| Audit Fee | 3.45 | 3.20 |
| Tax Audit Fee | 0.60 | 0.60 |
| Limited review and Certification work | 0.80 | 0.95 |
| Total | 4.85 | 4.75 |

Note 33 Income Taxes

As per Ind As 12 An explanation of the relationship between tax expense (income) and accounting profit in either or both of the following forms need to be disclosed:

- a numerical reconciliation between tax expense (income) and the product of accounting profit multiplied by the applicable tax rate, disclosing also the basis on which the applicable tax rate is computed; or
- a numerical reconciliation between the average effective tax rate and the applicable tax rate, disclosing also the basis on which the applicable tax rate is computed; The above said reconciliation will not arise in situations where there is accounting losses to taxable Income.

Notes to financial statements for the year ended 31st March, 2020
Note 34 Financial instruments – Fair values and risk management

(INR in Lakhs)

| 31st March, 2020 | Carrying amount | | | Fair value | | | | |
|--|------------------|---------------|----------|------------------|-------------|--------------|---------------|---------------|
| | Amortised Cost | FVTPL | FVTOCI | Total | Level 1 | Level 2 | Level 3 | Total |
| Non-Current Financial Assets | | | | | | | | |
| Investments | | | | | | | | |
| Quoted Equity Instruments | - | - | - | - | - | - | - | - |
| Unquoted Equity Instruments* | - | 71.10 | - | 71.10 | - | 71.10 | - | 71.10 |
| Unquoted Preference Shares | - | 470.86 | - | 470.86 | - | - | 470.86 | 470.86 |
| Other Financial Assets | - | 0.24 | - | 0.24 | - | - | 0.24 | 0.24 |
| Current Financial Assets | | | | | | | | |
| Current Investments | - | 0.11 | - | 0.11 | 0.11 | - | - | 0.11 |
| Trade Receivables | 2,364.94 | - | - | 2,364.94 | - | - | - | - |
| Cash and Cash Equivalents | 72.66 | - | - | 72.66 | - | - | - | - |
| Other Bank Balances | 11.80 | - | - | 11.80 | - | - | - | - |
| Loans | 3.65 | - | - | 3.65 | - | - | - | - |
| Other Financial Assets | 5.20 | - | - | 5.20 | - | - | - | - |
| | 2,458.25 | 542.31 | - | 3,000.56 | 0.11 | 71.10 | 471.10 | 542.31 |
| Non-Current Financial Liabilities | | | | | | | | |
| Borrowings | 3,453.93 | - | - | 3,453.93 | - | - | - | - |
| Current Financial Liabilities | | | | | | | | |
| Borrowings | 2,464.97 | - | - | 2,464.97 | - | - | - | - |
| Trade Payables | 4,046.43 | - | - | 4,046.43 | - | - | - | - |
| Other Financial Liabilities | 949.97 | - | - | 949.97 | - | - | - | - |
| | 10,915.30 | - | - | 10,915.30 | - | - | - | - |

(INR in Lakhs)

| 31st March, 2019 | Carrying amount | | | Fair value | | | | |
|--|------------------|---------------|----------|------------------|-------------|--------------|---------------|---------------|
| | Amortised Cost | FVTPL | FVTOCI | Total | Level 1 | Level 2 | Level 3 | Total |
| Non-Current Financial Assets | | | | | | | | |
| Investments | | | | | | | | |
| Quoted Equity Instruments | - | - | - | - | - | - | - | - |
| Unquoted Equity Instruments | - | 59.38 | - | 59.38 | - | 59.38 | - | 59.38 |
| Unquoted Preference Shares | - | 590.00 | - | 590.00 | - | - | 590.00 | 590.00 |
| Other Financial Assets | - | 0.24 | - | 0.24 | - | - | 0.24 | 0.24 |
| Current Financial Assets | | | | | | | | |
| Current Investments | - | 0.11 | - | 0.11 | 0.11 | - | - | 0.11 |
| Trade Receivables | 2,858.97 | - | - | 2,858.97 | - | - | - | - |
| Cash and Cash Equivalents | 34.02 | - | - | 34.02 | - | - | - | - |
| Other Bank Balances | 11.42 | - | - | 11.42 | - | - | - | - |
| Loans | 3.65 | - | - | 3.65 | - | - | - | - |
| Other Financial Assets | 5.04 | - | - | 5.04 | - | - | - | - |
| | 2,913.10 | 649.73 | - | 3,562.83 | 0.11 | 59.38 | 590.24 | 649.73 |
| Non-Current Financial Liabilities | | | | | | | | |
| Borrowings | 3,478.72 | - | - | 3,478.72 | - | - | - | - |
| Current Financial Liabilities | | | | | | | | |
| Borrowings | 2,333.37 | - | - | 2,333.37 | - | - | - | - |
| Trade Payables | 4,379.80 | - | - | 4,379.80 | - | - | - | - |
| Other Financial Liabilities | 1,003.32 | - | - | 1,003.32 | - | - | - | - |
| | 11,195.21 | - | - | 11,195.21 | - | - | - | - |

Level 1: Level 1 hierarchy includes financial instruments measured using quoted prices.

Level 2: The fair value of instrument is determined using valuation techniques which maximise the use of observable market data and rely as little as possible on entity-specific estimates. If all significant inputs required to fair value an instrument are observable, the instrument is included in level 2.

Level 3: If one or more of the significant inputs is not based on observable market data, the instrument is included in level 3.

Notes to financial statements for the year ended 31st March, 2020

Note 35 Financial risk management

The Company has exposure to the following risks arising from financial instruments:

- Credit risk ;
- Liquidity risk ; and
- Market risk

(A) Credit risk

Credit risk arises from cash and cash equivalents, deposits with banks, security deposits, as well as credit exposure to outstanding receivables.

Credit risk management

The Company is exposed to credit risk from its operating activities (primarily trade receivables) and from its financing activities, including deposits with banks and other financial instruments. For banks and other financial institutions, only high rated banks/ financial institutions are accepted. The balances with banks, loans given to employees, security deposits are subject to low credit risk and the risk of default is negligible or nil. Hence, no provision has been made for expected credit loss for credit risk arising from these financial assets.

Trade receivables

Credit risk arises from the possibility that customer will not be able to settle their obligations as and when agreed. To manage this, the Company periodically assesses the financial reliability of customers, taking into account the financial condition, current economic trends, analysis of historical bad debts, ageing of accounts receivable and forward looking information. Individual credit limits are set accordingly. The credit risk is considered low given the past experience of negligible or minimal write-offs.

The ageing of trade receivables are as follows:

(INR in Lakhs)

| | 31st March 2020 | 31st March 2019 |
|--------------------------------|-----------------|-----------------|
| Not past due date | 1,711.12 | 2,403.36 |
| Past due 1–90 days | 249.78 | 179.02 |
| Past due 91–180 days | 207.97 | 127.38 |
| Past due more than 180 days | 196.07 | 149.21 |
| Total Trade receivables | 2,364.94 | 2,858.97 |

(B) Liquidity risk

Liquidity risk is the risk that the Company may encounter difficulty in meeting its obligations. The Company monitors rolling forecast of its liquidity position on the basis of expected cash flows. The company has obtained fund based / Non-fund based working capital facilities from banks.

Exposure to liquidity risk

The tables below analyse the Company's non-derivative financial liabilities into relevant maturity group based on their contractual maturities:

(INR in Lakhs)

| 31st March, 2020 | < 1 year | 1 to 3 years | > 3 years |
|---|-----------------|---------------|-----------------|
| Non-derivative liabilities | | | |
| Borrowings | 2,464.97 | 875.15 | 2,578.78 |
| Trade payables | 4,046.43 | - | - |
| Other financial liabilities | 949.97 | - | - |
| Total non-derivative liabilities | 7,461.37 | 875.15 | 2,578.78 |

| 31st March, 2019 | < 1 year | 1 to 3 years | > 3 years |
|---|-----------------|---------------|-----------------|
| Non-derivative liabilities | | | |
| Borrowings | 2,333.37 | 818.15 | 2,660.57 |
| Trade payables | 4,379.80 | - | - |
| Other financial liabilities | 1,003.32 | - | - |
| Total non-derivative liabilities | 7,716.49 | 818.15 | 2,660.57 |

Notes to financial statements for the year ended 31st March, 2020
(C) Market risk
(i) Foreign currency risk

Foreign currency risk means the risk that the result or economic situation of the Company changes due to changes in exchange rates. The Company is exposed to foreign exchange risk arising from foreign currency transactions, primarily with respect to the USD. Foreign exchange risk arises from future commercial transactions and recognised assets and liabilities denominated in a currency which is not the Company's functional currency (INR). The risk is measured through a forecast of highly probably foreign currency cash flows.

(a) The Company's exposure to foreign currency risk at the end of the year are as follows :-

(INR in Lakhs)

| Particulars | Currency | Exposure in F.C. | Exposure in INR |
|---|------------|------------------|-----------------|
| Financial Assets | | | |
| Trade receivables | USD | | |
| As at March 31,2020 | | 14.59 | 1,087.83 |
| As at March 31,2019 | | 15.95 | 1,079.82 |
| Financial Liabilities | | | |
| Trade Payables | USD | | |
| As at March 31,2020 | | 0.01 | 0.89 |
| As at March 31,2019 | | 0.13 | 8.65 |
| Net Exposure as at March 31,2020 | | 14.58 | 1,086.94 |
| Net Exposure as at March 31,2019 | | 15.82 | 1,071.17 |

(b) Sensitivity analysis:

(INR in Lakhs)

| | Impact on profit before tax | |
|---------------------------|-----------------------------|-----------------|
| | 31st March 2020 | 31st March 2019 |
| USD sensitivity | | |
| INR/USD -Increase by 5% * | 54.35 | 53.56 |
| INR/USD -Decrease by 5% * | (54.35) | (53.56) |

*Holding all other variables constant

(ii) Interest rate risk

Interest rate risk is the risk that the fair value or future cash flows of a financial instrument will fluctuate because of changes in market interest rates. The interest rate risk can also impact the provision for retiral benefits. The Company Interest rate risk is linked to PLR rates therefore subject to interest rate risk, carrying amount and future cash flows will fluctuate because of change in the market interest rates (PLR Rates).

Sensitivity:

(INR in Lakhs)

| | Impact on profit before tax | |
|--------------------------|-----------------------------|-----------------|
| | 31st March 2020 | 31st March 2019 |
| Change | | |
| 25 Basis Points increase | (16.51) | (14.96) |
| 25 Basis Points decrease | 16.51 | 14.96 |

Notes to financial statements for the year ended 31st March, 2020
Note 36 Capital Management

The Company's objective for capital management is to maximize shareholder wealth, safeguard business continuity and support the growth of the Company. The Company determines the capital management requirement based on annual operating plans and long-term and other strategic investment plans. The funding requirements are met through optimum mix of borrowed and own funds.

The Company's adjusted net debt to equity position are as follow:

(INR in Lakhs)

| Particulars | 31st March 2020 | 31st March 2019 |
|---------------------------------|-----------------|-----------------|
| Net debt | 5,918.89 | 5,812.09 |
| Less: Cash and Cash Equivalents | 84.46 | 45.44 |
| Less: Current Investments | 0.11 | 0.11 |
| Adjusted net (Cash)/Debt | 5,834.33 | 5,766.54 |
| Total equity | 1,382.00 | 2,324.45 |
| Net debt to equity ratio | 4.22 | 2.48 |

Note 37 Segment Reporting

The business activities of the Company from which it earns revenues and incurs expenses; whose operating results are regularly reviewed by the chief operating decision maker to make decisions about resources to be allocated to the segment and assess its performance, and for which discrete financial information is available which involves predominantly one operating segment i.e. automotive components.

Note 38 - Contingencies and commitments

(INR in Lakhs)

| Particulars | 31st March 2020 | 31st March 2019 |
|---|-----------------|-----------------|
| Contingent Liabilities: | | |
| a. Income Tax matter under appeal approx | 14.50 | 66.22 |
| b. Sales Tax matter under appeal | 181.05 | 235.47 |
| c. Excise Duty in dispute | 294.19 | 460.38 |
| d. ESIC liability in dispute | 1.26 | 1.26 |
| e. Municipal property Tax in dispute | 9.16 | 9.16 |
| f. Labour Cases | 50.54 | 50.54 |
| g. Entry Tax in dispute | 10.13 | 10.13 |
| h. Other Compensation Matters | 20.00 | 20.00 |
| i. Claim against Company not acknowledged as debt | 26.07 | 26.07 |
| Commitments : | | |
| On Capital Account | 333.12 | 579.93 |

Note 39 Earnings per share

(INR in Lakhs)

| Particulars | 31st March 2020 | 31st March 2019 |
|--|-----------------|-----------------|
| Basic and diluted earnings per share | | |
| a) Profit attributable to the equity holders of the | (942.45) | (881.19) |
| b) Weighted average number of equity shares outstanding (Nos.) | 17,708,621 | 17,708,621 |
| c) Earnings per share - Basic and diluted | (5.32) | (4.98) |

Notes to financial statements for the year ended 31st March, 2020

Note 40 Company has purchased six bills of exchange and paid Rs. 206.65 Lakhs (Rs. 206.65 Lakhs) for the same. These bills have matured but have not been honoured. Company has filed suits in the High Court of Judicature at Bombay.

Note 41 Issue of **4550** (4550) Bonus Shares and **480** (480) Rights shares have been kept in abeyance as per the provisions of the Companies Act.

Note 42 In terms of the Notification dated 31st March, 2009 by The Ministry of Corporate Affairs amending the erstwhile Ind AS -21 "The Effects of Changes in Foreign Exchange Rates", the company had exercised the option to recognize the exchange difference on long term non-monetary items retrospectively from the accounting period 2007-08. Such exchange differences relating to the acquisition of capital assets are adjusted to the cost of capital and would be depreciated over the balance life of the asset. Exchange difference amounting to Rs.1125.13 Lakhs (Rs.1334.86 Lakhs) has been carried in the Fixed Assets as on 31st March, 2020.

Note 43 Disclosure as required under Micro Small and Medium Enterprises Development Act, 2006 (INR in Lakhs)

| PARTICULARS | As at 31 st March, 2020 |
|--|------------------------------------|
| i. Principal amount remaining unpaid to any supplier as at the end of the accounting year | 443.16 |
| ii. Interest due thereon remaining unpaid to any supplier as at the end of the accounting year | 26.31 |
| iii. The amount of interest paid along with the amounts of the payment made to the supplier beyond the appointed day | - |
| iv. The amount of interest due and payable for the year | 26.31 |
| v. The amount of interest accrued and remaining unpaid at the end of the accounting year | 26.31 |

The information as required to be disclosed under Micro, Small and Medium Enterprises Development Act, 2006 is determined to the extent such parties have been identified on the basis of information made available with the company.

Note 44 In view of the expected growth in Indian Automobile Industry and business potential of the company, the company expects substantial growth in its turnover and financial position. Based on these future prospects, though the company has continuously incurred losses in previous years, the financial statements of the company have been prepared on going concern basis.

Note 45 Related Party Transactions

a) Name of Related Parties

Jaya Hind Sciaky Ltd.
 Kinetic Communications Ltd.
 Microage Instruments Pvt. Ltd.
 Kinetic Hyundai Elevator & Movement Technologies Ltd.
 Ducati Energia Pvt. Ltd.
 Kinetic Green Energy & Power Solutions Limited.
 MV Agusta India Private Limited.
 Motoroyale (India) Private Ltd. (Erstwhile Norton Motoroyale India Private Ltd.)

b) Key management personnel

| | |
|-------------------------|--|
| Chairman | Mr. A.H. Firodia |
| Managing Director & CFO | Mr. Ajinkya Firodia |
| Executive Director | Ms. Sulajja Firodia Motwani |
| Chief Executive Officer | Mr. Chaitanya Koranne |
| Company Secretary | Ms. Deepal Shah (Up to 3rd June, 2019) Mr. Nikhil Deshpande (From 15th Nov, 2019) |
| Non-executive directors | Dr. Jayashree Arun Firodia Mr. Ramesh Jankiram Kabra Mr. Shirish Ratanlal Kotecha Mr. Rajiv Ishwarlal Ranka Mr. Rohit Prakash Bafana |

Notes to financial statements for the year ended 31st March, 2020
c) Transactions and balances with related parties have been set out below:
(INR in Lakhs)

| Particulars | 31st March 2020 | 31st March 2019 |
|--|------------------------|------------------------|
| Jaya Hind Sciaky Ltd. | | |
| Reimbursement of Expenses | 2.21 | 0.53 |
| Kinetic Green Energy & Power Solutions Limited | | |
| Sales of Goods | 9.96 | 0.73 |
| Rendering of Services (Income) | - | 15.68 |
| Reimbursement of Expenses | 22.49 | 10.54 |
| Rent Received | 2.40 | 2.83 |
| Sale of Investment in Preference shares | 119.14 | 60.00 |
| Ducati Energia Pvt. Ltd. | | |
| Purchase of Goods | - | 1.09 |
| Sales of Goods | - | 0.42 |
| MV Agusta India Private Limited | | |
| Rent Received | - | 0.71 |
| Kinetic Hyundai Elevator & Movement Technologies Ltd. | | |
| Dividend Received | 3.60 | 3.60 |
| Kinetic Communications Ltd. | | |
| Dividend Received | 0.32 | - |
| Norton Motoroyale India Pvt. Ltd. | | |
| Sale of Goods | 1.43 | - |
| Mr. A. H. Firodia | | |
| Rent Paid | - | 0.05 |
| Remuneration to Key Managerial Persons | | |
| Mr. Ajinkya Firodia | 52.11 | 58.39 |
| Mr. Chaitanya Koranne | 46.85 | 51.53 |
| Ms. Deepal Shah | 1.93 | |
| Mr. Nikhil Deshpande | 7.17 | |
| Director Sitting Fee | | |
| Mr. Jinendra Hirachand Munot | - | 0.12 |
| Mr. Ramesh Jankiram Kaabra | 0.14 | 0.12 |
| Mr. Shirish Ratanlal Kotecha | 0.12 | 0.14 |
| Dr. Jayashree Arun Firodia | 0.10 | 0.08 |
| Mr. Rohit Prakash Bafna | 0.18 | - |
| Mr. Rajiv Ishwarlal Ranka | 0.08 | - |

As per our report of even date
For **Pawan Jain And Associates**
Chartered Accountants

Pawan Jain
Partner
Membership Number- 032900
Firm Reg No.:0107867W

Place : Pune
Date : 30th June, 2020

For and on behalf of Board of Directors
For **Kinetic Engineering Limited**

A. H. Firodia
(Chairman)
DIN:00057324

A. A Firodia
(Managing Director & CFO)
DIN:00332204

Chaitanya Koranne **Nikhil Deshpande**
(Chief Executive Officer) (Company Secretary)

KYC FORM

To,
Linkintime India Private Limited
C-101,247 Park, L.B.S. Marg, Vikhroli (West),
Mumbai -400083
Unit: KinetiC Engineering Limited

Date:
Folio No.:
No. of shares:

Dear Sir/Madam,
We refer to the current KYC status as provided by you in the below table:

| Name of the shareholder(s) | PAN | Bank details | Specimen Signature | Email id | Mobile no. Details | Nominee |
|----------------------------|-----|--------------|--------------------|----------|--------------------|---------|
| | (A) | (B) | (C) | (D) | (E) | (F) |
| | | | | | | |

Based on the above data, we are forwarding herewith, the required supporting documents by ticking in the appropriate checkbox below for all the fields where the status is shown as "required" in the above table.

A. For registering PAN of the registered and/or joint shareholders (as applicable)

| | |
|------------------------|--|
| Registered shareholder | |
| Joint Holder 1 | |
| Joint Holder 2 | |
| Joint Holder 3 | |

* Self attested copy for all shareholders should be attached.

B. For registering Bank details of the registered shareholder

| | |
|--------------------------------|--|
| Aadhar/passport/utility bill | |
| Original cancelled cheque leaf | |
| Bank passbook/Bank statement | |

C. For registering the specimen signature of registered and/or joint shareholders (as applicable)

| | |
|--------------------------------|--|
| Affidavit | |
| Banker verification | |
| Original cancelled cheque leaf | |
| Bank passbook/Bank statement | |

D. For updating the email id: _____

E. Mobile No. :

F. For registering Nominee Details by the registered shareholder: Form SH-13

Note: For residents of Sikkim, instead of PAN provide Aadhar card/ Voter id/ Driving License/ Passport or any other ID proof issued by Govt.

I/We hereby state that the above mentioned details are true and correct and we consent towards updating the particulars based on the self-attested copies of the documents enclosed with this letter by affixing my/our signature on it.

Sign _____ Sign _____ Sign _____ Sign _____
Registered holder Joint holder 1 Joint holder 2 Joint holder 3

VISION



KINETIC

A KINETIC IN EVERY AUTOMOBILE

Building on its strong technical knowledge, 4 decades of manufacturing experience, vertically integrated in-house capability and customer-oriented attitude, Kinetic aspires to provide a system or its parts in every automobile in the world.

PROMISE

- 1 QUALITY
- 2 COST COMPETITIVE
- 3 DELIVERY
- 4 INNOVATION
- 5 BEST PRACTICES



We will leverage our technical strength to deliver to our customers high-quality systems and components at competitive prices, in a timely manner by continuous upgradation, innovation and best practices in the auto industry.

QUALITY POLICY

Kinetic Engineering Limited shall consistently produce products of high quality at competitive prices through excellence in design, engineering, manufacturing and service.

This policy shall be deployed through:

- Customer focus in all decisions*
- Continuous improvement*
- Development of capable supplier base*
- Active participation of workforce*



With over 45 years of automobile manufacturing experience and winner of "Export Excellence awards" for 5 consecutive years, Kinetic Engineering Limited has complete capability from forgings to grinding with latest gear manufacturing machinery including laser welding and an International standard assembly line.

www.KineticIndia.com