



CELEBRATING 50 YEARS OF KINETIC

KEL:SH:SE:

Date: 1st August, 2025

To
The Manager - Corporate Relationship Department
BSE Limited, 1st Floor,
Phiroze Jeejeebhoy Towers,
Fort, Mumbai- 400 001
Maharashtra, India

Scrip Code: BSE-500240

Subject: Investor Presentation

Dear Sir/Madam,

Pursuant to Regulation 30 of the SEBI (Listing Obligations and Disclosure Requirements) Regulations 2015, we are enclosing herewith the Investor Presentation.

This is for your information and records.

Thanking you.

Yours faithfully,

For Kinetic Engineering Limited

Chaitan
ya
Mundra

Digitally signed
by Chaitanya
Mundra
Date: 2025.08.01
10:12:18 +05'30'

Chaitanya Mundra
Company Secretary and Compliance Officer

KINETIC ENGINEERING LTD

Registered Address:
D1 Block, Plot No.18/2,
Chinchwad, Pune
Maharashtra India 411019

Factory Address:
Kinetic Manufacturing Plant
Nagar-Daund Road, Ahmednagar
Maharashtra India 414001

Contact: +91 2066142049
Email ID: kelinvestors@kineticindia.com
Website: www.kineticindia.com
CIN: L35912MH1970PLC014819

KINETIC ENGINEERING LTD.

INVESTOR PRESENTATION

Q1 FY26

Refer to Disclaimer

DISCLAIMER

This document has been prepared for information purposes only and is not an offer or invitation or recommendation to buy or sell any securities of Kinetic Engineering Ltd. (“Kinetic Engineering”, “KEL”, “Company”), nor shall part, or all, of this document form the basis of, or be relied on in connection with, any contract or investment decision in relation to any securities of the Company. This document is strictly confidential and may not be copied, published, distributed or transmitted to any person, in whole or in part, by any medium or in any form for any purpose. The information in this document is being provided by the Company and is subject to change without notice. The Company relies on information obtained from sources believed to be reliable but does not guarantee its accuracy or completeness. This document contains statements about future events and expectations that are forward-looking statements. These statements typically contain words such as “expects” and “anticipates” and words of similar import. Any statement in this document that is not a statement of historical fact is a forward-looking statement that involves known and unknown risks, uncertainties and other factors which may cause our actual results, performance or achievements to be materially different from any future results, performance or achievements expressed or implied by such forward-looking statements. None of the future projections, expectations, estimates or prospects in this document should be taken as forecasts or promises nor should they be taken as implying any indication, assurance or guarantee that the assumptions on which such future projections, expectations, estimates or prospects have been prepared are correct or exhaustive or, in the case of the assumptions, fully stated in the document. The Company assumes no obligations to update the forward-looking statements contained herein to reflect actual results, changes in assumptions or changes in factors affecting these statements. You acknowledge that you will be solely responsible for your own assessment of the market and the market position of the Company and that you will conduct your own analysis and be solely responsible for forming your own view of the potential future performance of the business of the Company.



01. ABOUT US

02. BUSINESS OVERVIEW

03. KEL: VALUE DRIVERS

04. FINANCIAL HIGHLIGHTS

05. WAY FORWARD

06. ANNEXURE

TABLE OF CONTENT

ABOUT US

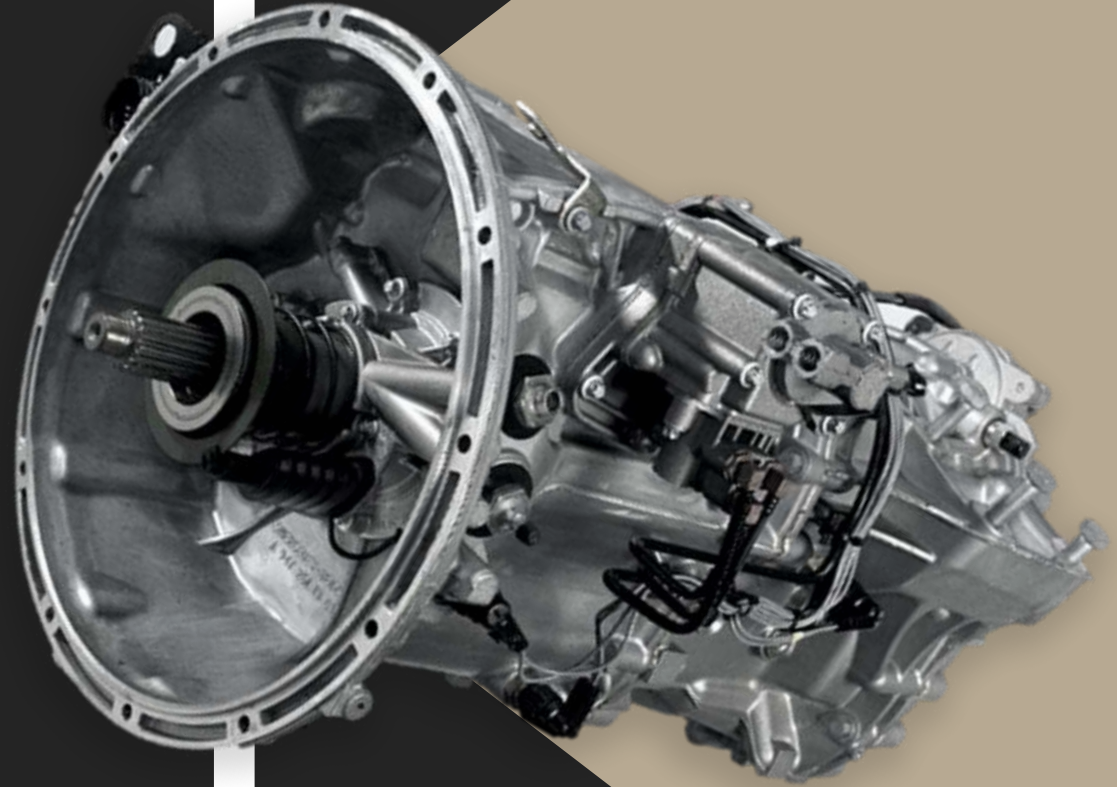

OUR JOURNEY



1975

Converted to a **public limited company** on **October 1**.



1972

The company was established and began operations **with the launch of the Kinetic Luna moped**, which **achieved significant domestic sales and exports**.



1970

KEL was **founded** by **H.K. Firodia**.



1984

Formed a **joint venture with Honda Motor Company**, introducing Kinetic Honda scooters with electric start and gearless transmissions.



1998

Kinetic **acquired Honda's stake in the joint venture**, rebranding as Kinetic Motors.



2008

Entered into a **joint venture with SYM a Taiwanese motorcycle company**, to bring new products to Indian market.



2024-25

New Additions:

- **Nylon Coating unit**
 - **Automated welding facility**
 - **Solar power project**
- (The Solar project is projected to save Rs. 6 Crore annually)



2022

Kinetic **Watts & Volts** was formed in September 2022 as a subsidiary of Kinetic Engineering with a **vision to provide integrated solutions for EV customers**.



2011

Shifted **focus to automotive components manufacturing, supplying to various industries**, including automotive and off-highway applications.

LEAD MANAGEMENT

Late Mr. H.K. Firodia - The Doyen of Indian Automobile

Mr. H.K. Firodia, fondly known as the Doyen of the Indian Automobile Industry, played a pivotal role in shaping iconic companies like Bajaj Auto, Force Motors, and Kinetic Honda. He was instrumental in laying the foundation of India's thriving automobile sector, leaving behind a proud legacy for the Kinetic Group.

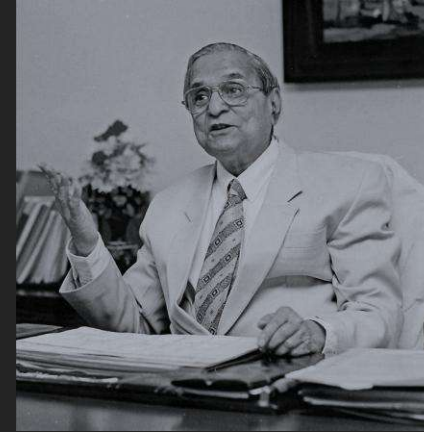

Padma Shri Dr. Arun Firodia - Chairman

Padma Shri Dr. Arun Firodia, the chairman of Kinetic Group is an epitome of the combination of a brilliant engineer and an astute businessman' Apart from being a leading industrialist, Dr. Arun Firodia is also a prominent social activist' Born to Shri H.K. Firodia in 1943, Dr. Arun Firodia obtained his B. Tech degree with distinction in Electrical Engineering from IIT Mumbai in 1965. He continues the rich tradition of his distinguished father, Late Shri H K Firodia.



Ajinkya Firodia - Vice Chairman & Managing Director

Ajinkya Firodia, Vice Chairman & Managing Director of Kinetic Engineering Ltd., is a distinguished industrialist from the Firodia family, pioneers in the Indian automobile industry. He graduated from Brown University, USA. He holds a double degree in engineering & economics and began his career as an M&A analyst at J.P. Morgan Chase.



"To drive innovation and excellence in the automotive industry by delivering high-quality components, embracing sustainable technologies"

MISSION

Innovation and Excellence: KEL emphasizes continuous innovation and strives for excellence in engineering, aiming to set industry benchmarks.

Sustainable Technologies: The company is actively investing in the electric vehicle (EV) sector, reflecting its commitment to sustainable and future-ready technologies.

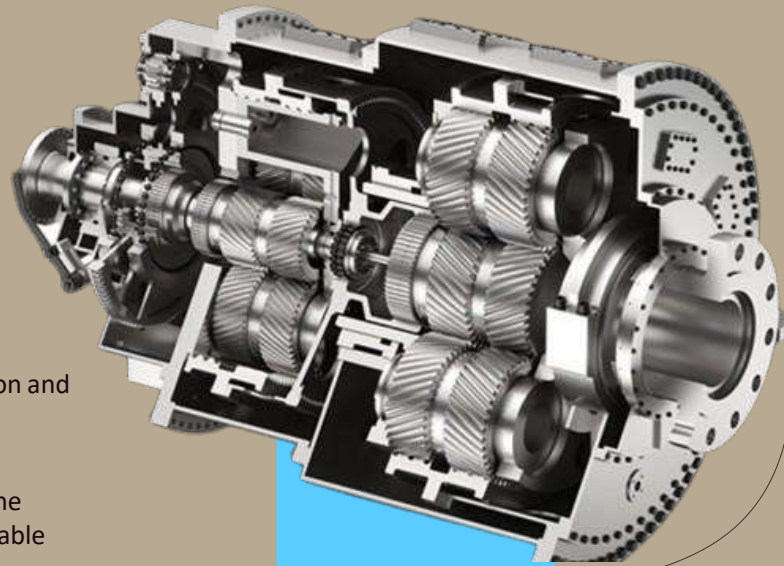

VISION

To be a global leader in automotive and mobility solutions, driving innovation and embracing sustainability through cutting-edge engineering and manufacturing excellence.

KINETIC GROUP COMPANIES



BUSINESS OVERVIEW

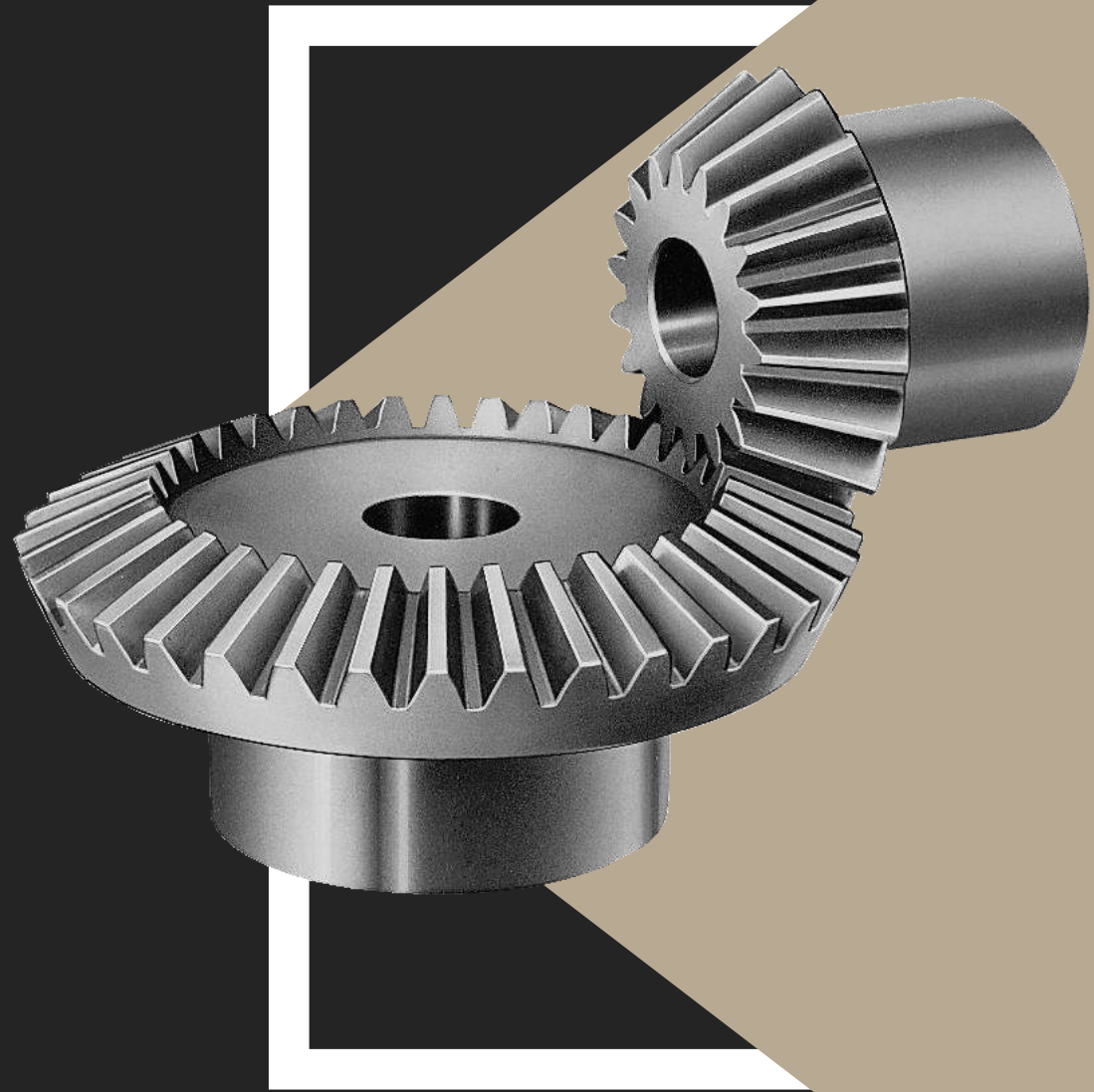

GROUP STRUCTURE



1. Kinetic Engineering Ltd (KEL)

Transmission Vertical: Gearboxes, Planet Gears, Sun Shafts.

Driveline Vertical: Spline Yoke, Stub Shaft.

EV Vertical: Rigid Axles, Trans Axles, Chassis Bodies, 2 Wheeler GB Assembly.

Customer Base: Supplies to major OEMs such as Tata Motors, Mahindra, Ashok Leyland, etc. & export market.

2. Kinetic Communication Ltd (KCL)

KCL develops and manufactures Complete EV powertrain solutions for 2w & 3w:

- BLDC Hub Motors
- Motor Controllers
- EV Battery Chargers

Group Company (0.3% Equity)

3. Micro Age Instruments Pvt. Ltd. (MAIPL)

- EV battery manufacturing under the Range-X brand.
- Annual production capacity of 60,000 units.
- Batteries will be used for captive consumption and sales to other OEMs.

Associate Company (24.9% Equity)

4. Kinetic Watts & Volts Ltd. (KWVL)

- Design Development and manufacturing of EV mobility Solutions.
- Will integrate components from KEL (mechanical), KCL (electrical), and MAIPL (battery).

Subsidiary Company (72.5% Equity)

1. Kinetic Engineering Limited



Kinetic Engineering Limited (KEL) has Over **50 years of legacy** in India's auto industry. Founded by **Late Mr. H.K. Firodia**.



Creator of the iconic:

- **Kinetic Luna**
- **Kinetic DX** - India's first gearless scooter.
- **Blaze 165 cc** - India's first moto scooter.



Three Key Verticals:

- **Transmission Vertical**
- **Driveline Vertical**
- **EV Vertical**



Manufacturing facility spread over **50+ acres** in **Ahmednagar, Maharashtra** with **1000+ employees**.



Certified with **IATF 16949**, a globally recognized quality standard, reinforcing the company's commitment to world-class automotive manufacturing excellence.



BUSINESS PROCESS

Raw Material Procurement

Sourcing high-quality raw materials such as steel, Aluminium, and alloys.

Establishing vendor partnerships for cost-efficient and timely procurement.



Forging & Machining

Forging & casting of essential components like gears, shafts, axles, and chassis parts.

Precision machining for enhanced durability and performance.



Component Manufacturing

Production of gearboxes, shafts, differential assemblies, rigid axles, and powertrain components for ICE and EV vehicles.

Supply of chassis, driveline solutions, and transmission parts for two-wheeler and three-wheeler EVs.

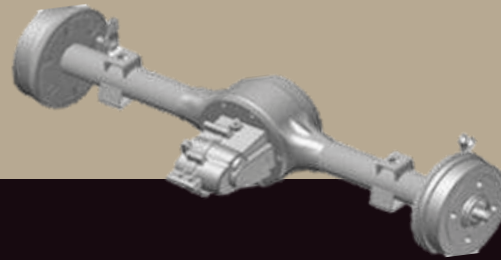

Quality Control & Testing

Implementing stringent quality checks and durability testing to ensure industry standards.

Testing for load-bearing capacity, performance, and efficiency.

Assembly & Integration

Integration of components into full assemblies before supplying to OEMs.

Ensuring compatibility with ICE, hybrid, and EV powertrains.

Distribution & Supply Chain Management

Supplying to domestic and international OEMs, Tier-1 suppliers, and aftermarket distributors.

Managing logistics to optimize cost and delivery efficiency.

TRANSMISSION VERTICAL

Gears & Gearbox Expertise

With 50+ years of experience, specialize in custom gears and constant mesh gearboxes, delivering tailored, high-quality solutions for optimal performance and reliability.



Planet Gear



Gearboxes

Shaft & Sleeves

Manufactures high-quality shafts and precision sleeves, ensuring smooth transmission and enhanced performance in automotive applications.



Sun Shaft



Shifter Sleeve

Broached Parts & Knuckle Assembly

Kinetic Engineering utilizes advanced broaching technology and expertise to deliver precision broached parts and knuckle assemblies, ensuring top-quality performance and compliance with automotive standards.



Disk Brake Tow Hub



Knuckle Assembly



Spline Yoke

Spline yoke components are designed for exceptional durability and drivetrain efficiency, using advanced materials and manufacturing techniques.

Ideal for passenger, commercial, and specialty vehicles, they ensure superior performance and reliability in all driving conditions.

DRIVELINE VERTICAL



Stub Shaft

Team of skilled engineers ensures each stub shaft is precision engineered to meet or exceed industry standards for accuracy and surface finish, delivering exceptional performance and durability for the automotive industry.

EV (2W & 3W) Vertical



Rigid Axle

Specialized in high-performance rigid axles, engineered for **exceptional durability** and **seamless power transmission**, ensuring **reliable performance in commercial and passenger vehicles**.

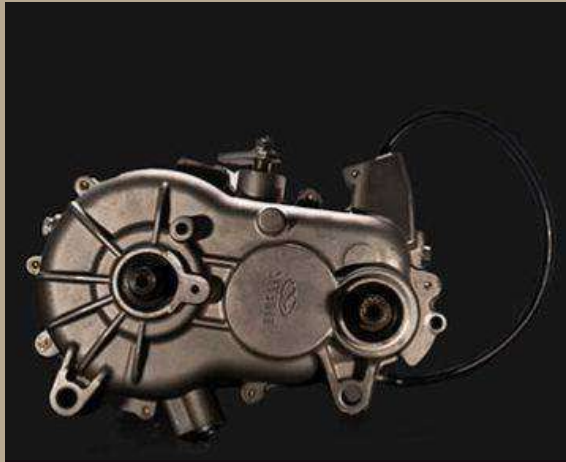

Trans Axle

Kinetic Engineering specializes in high-performance trans-axles, designed for **seamless power transmission** and **efficient integration** across diverse vehicle applications, ensuring **optimal performance and reliability**.



Chassis and body parts

The **Electric two Wheelers chassis** features an **innovative design** and **meticulous craftsmanship**, delivering **exceptional performance and durability**.



2-Wheeler GB Assembly

Kinetic Engineering pioneers innovative 2-wheeler GB Assemblies, enhancing electric mobility with **seamless performance**.

2. Kinetic Communications Ltd.

Group company - (0.3% Equity)

Founded in 1995 by Padmashri Dr.
Arun Firodia

KCL Develops and manufactures complete
EV powertrain solutions for electric
2-wheelers and 3-wheelers.



BLDC Hub Motor



EV battery Charger



Offers the wide range of customized EV powertrain solutions for
2W & 3W:

- BLDC hub motors & frame-mounted motors
- BLDC & Controllers
- Touchscreen display clusters with navigation & mirroring
- DC-DC converters & EV battery chargers

Facility: Pimpri-Chinchwad, Pune.

3. Mirco Age Instruments Pvt Ltd.

Associate company - (24.9% Equity) | Promoters Holding – (34.4% Equity)

Micro Age Instruments Pvt. Ltd. **established in 1980**

**Recent Strategic Shift to:
EV Battery Manufacturing**



RANGE-X

Commissioned a **battery manufacturing plant**

Annual Capacity - 60,000 units

Facility: Ahmednagar, Maharashtra.

This facility aims to produce **advanced LFP & NMC EV batteries** aligning with the growing demand for electric vehicle.

4. Kinetic Watts & Volts Ltd.

Subsidiary company - (72.5% Equity)

Established - September 2022

A subsidiary of Kinetic Engineering Ltd:

KWVL is the group's dedicated venture into the **electric vehicle (EV)** segment **acts as Design, Development & manufacturing unit** within Kinetic Group's EV supply chain. The new Kinetic DX model has been relaunched under KWV.



THE RE-INCARNATION

KINETIC DX

KINETIC DX+



KINETIC RE-ENTERS TWO-WHEELER MARKET

Introducing the All-New Electric Kinetic DX & DX+ Launched under its EV subsidiary Kinetic Watts and Volts Ltd., KEL revives its iconic DX scooter in a modern electric avatar. Kinetic DX, a household name from the 90s, reborn with cutting-edge EV tech.

Strategic Backing

₹ 72 Cr already invested in KVV;
promoters are aiming to further invest
₹177 Cr to scale the DX platform.

Battery & Performance:

Range up to
116KM

Powered by **Range-X 2.6 kWh** LFP battery with up to **116 km IDC range** (DX+)

4x Longer
Performance

4x longer lifecycle (2,500–3,500+ cycles) vs. typical NMC batteries

Thermal
Sensitivity

Better **thermal sensitivity**, making it safer in Indian conditions

K-Coast Tech

60V system with **K-Coast regenerative technology** for high efficiency

Charging

0-50% charge in **2 hours**; **0-100%** charge in **4 hours**



MANUFACTURING PLANT - AHMEDNAGAR

AHMEDNAGAR FACTORY
est 1970



50+
Acres

32+
Production Sheds

460+
Robust Machines

Ahmednagar Factory

Employs 1,000+ people.

Serves Key automation segments:

- Commercial Vehicles
- Passenger Car
- Tractor
- Two-Wheelers



IATF 16949 Certified

A mark of global quality compliance in
automotive manufacturing.

INFRASTRUCTURE AT THE PLANT

FORGINGS



GEAR CUTTING



PAINTING & PLATING



HEAT TREATMENT



PRECISION MACHINING



ELETRICDIVISION



OUR CUSTOMERS

INTERNATIONAL



DOMESTIC



KEL: VALUE DRIVERS

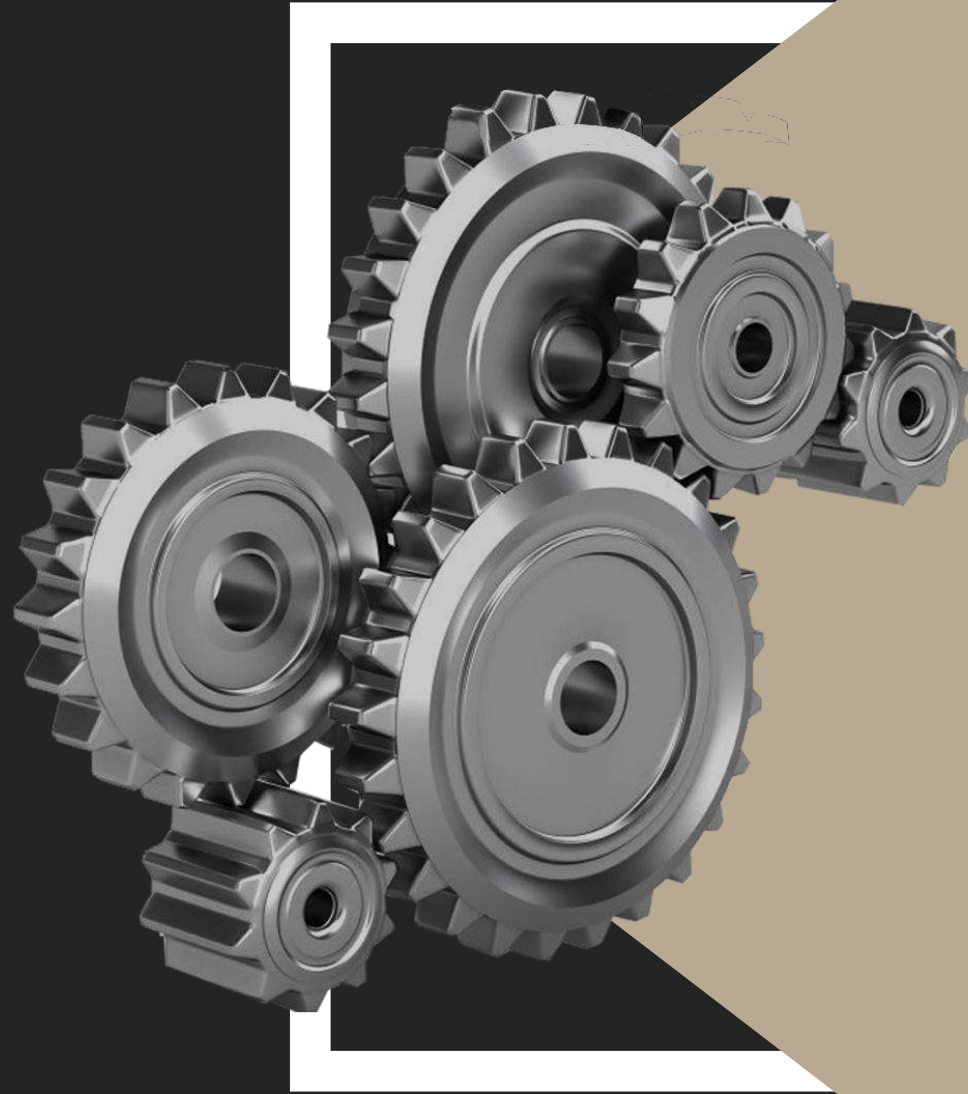

EVOLUTION OF KEL

Phase 1 (1972-2010)

The phase when legacy was built

- Pioneered India's two-wheeler revolution with **Kinetic Luna** and **Kinetic DX - iconic scooters**.
- Formed a successful JV with Honda (**Kinetic Honda Motor Company**).
- Expanded presence in domestic and international markets with strong product portfolio.
- Built large-scale manufacturing & R&D infrastructure in **Ahmednagar**.

Phase 2 (2011-2022)

The phase of realignment and strengthening of core

- Transitioned focus from **vehicle manufacturing to auto component manufacturing**.
- Developed expertise in **drivetrain, transmission components, and precision engineering**.
- Expanded OEM partnerships across domestic and international markets.
- Promoter group gradually increased stake, indicating confidence in revival.
- Formed EV-focused subsidiaries like **Kinetic Watts & Volts Ltd**.

Phase 3 (2023 & Beyond)

The phase drive the future of mobility

- Set up advanced battery manufacturing unit (**Range-X**) in MAIPL with **60,000 units/year capacity**.
- Investing in EV drivetrain & transmission systems, **targeting 2W/3W OEMs**.
- Focused on **green mobility, electrification and expanding export markets**.

What lies ahead?

- Leverage strong promoter vision to tap into **India's growing EV ecosystem**.
- Scale EV and component businesses through new capacities and product lines.
- Continue backward integration to reduce third-party dependency.

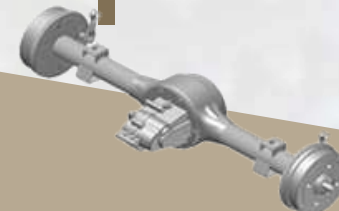
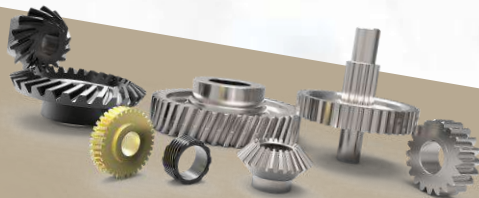
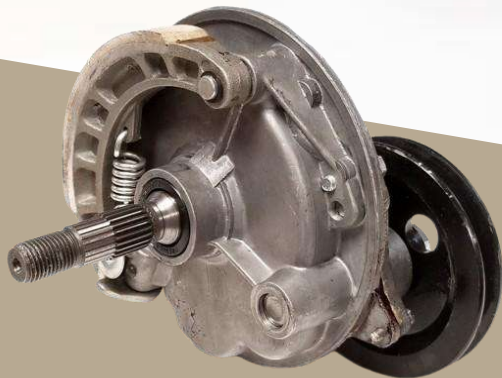

WHY KINETIC ENGINEERING?



50+ years of legacy in trusted automotive engineering.

Backward integrated operations ensuring **cost control and quality advantage**.

Expansion into EV components, battery manufacturing with **(Range-X brand)**.

Dedicated EV subsidiary: Kinetic Watts & Volts Ltd to capture India's booming **EV supply chain opportunity**.

PROMOTER COMMITMENT

Promoter have infused Rs. 160 Cr through warrants payable in tranches to fuel future growth.

PROMOTER CONFIDENCE & STRATEGIC COMMITMENT



Promoter Group Shareholding Pattern (%)

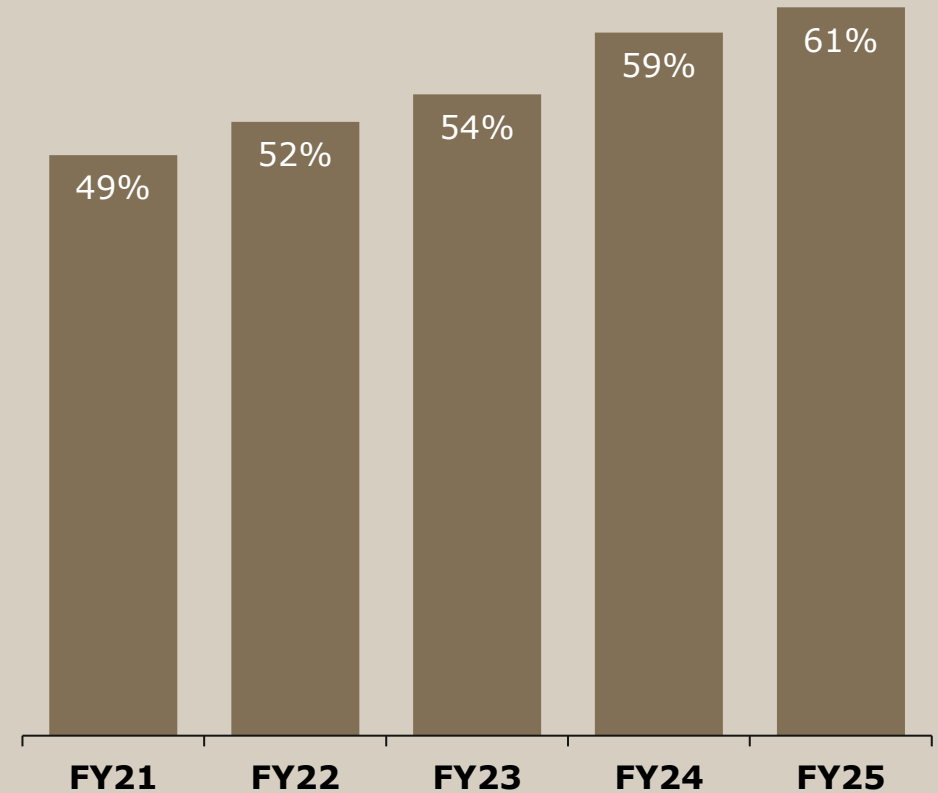

- The consistent increase in promoter shareholding reflects strong confidence in Kinetic Engineering's growth trajectory and the future of the EV and auto component industry.
- Demonstrates long-term bullishness towards both the business and the evolving EV ecosystem.
- Promoter Capital Infusion via Warrant. Details:

Date of Issue	Warrant Size (Rs.)	Issue price (Rs.)	No of warrants issued	Converted warrant till date
27-03-2025	160 Crores	171/-	93,56,725	11,69,591

COMPETITIVE STRENGTHS

Vertically Integrated Manufacturing

- In-house production of forgings, gearboxes, shafts, and chassis components.
- End-to-end manufacturing ensures cost efficiency and quality control.

Strong Legacy & Brand Recognition

- Over 50 years of experience in the automotive industry.
- Pioneer of Kinetic Luna and India's first gearless scooter (Kinetic Honda).

Diversified Product Portfolio

- Specialization in ICE (Internal Combustion Engine) and EV components.
- Supplies transmission, driveline, and chassis parts to multiple industries.

Focus on EV Growth & Sustainability

- Expanding into EV drivetrain systems, axles, and gear solutions.
- Strong synergy with Kinetic Watts & Volts and Range-X (EV-focused subsidiary) for future growth.

Robust R&D, Manufacturing & Engineering Capabilities

- Investment in CAD, CAM, and advanced material engineering.
- Focus on lightweight and high-performance auto components.

Strong OEM & Tier-1 Client Base

- Supplies to leading automotive OEMs and Tier-1 suppliers.
- Established domestic & export business across multiple geographies.



FINANCIAL HIGHLIGHTS

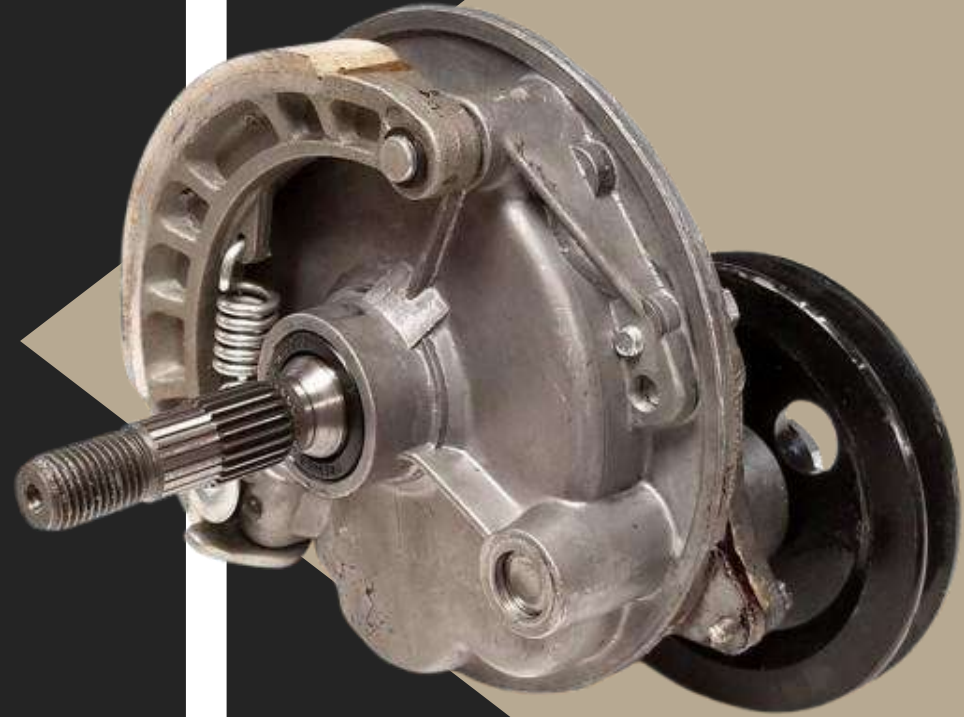

CONSOLIDATED QUARTERLY INCOME STATEMENT

Particular (INR Mn)	Q1FY26	Q4FY25	Q1FY25	YoY%	QoQ%	FY25	FY24
Net Sales	353.4	385.4	395.6	-10.7%	-8.3%	1,424.6	1,439.3
Other Income*	56.1	8.5	6.5	763.1%	560.0%	128.1	90.4
Total Income	409.5	393.9	402.1	1.8%	4.0%	1,552.70	1,529.70
Total expenditure	373.7	354.2	370.5	0.9%	5.5%	1,374.5	1,359.1
EBITDA	35.8	39.7	31.6	13.3%	-9.8%	178.2	170.6
EBITDA Margin (%)	8.7%	10.1%	7.9%	+88bps	-134bps	11.5%	11.2%
Depreciation	14.6	17.7	16.1	-9.3%	-17.5%	66.9	64.5
EBIT	21.2	22.0	15.5	36.8%	-3.6%	111.3	106.1
Interest	16.0	17.1	10.1	58.4%	-6.4%	49.0	54.5
PBT	5.2	4.9	5.4	-3.7%	6.1%	62.3	51.6
Tax	-	-	-	-	-	-	-
Reported PAT	5.2	4.9	5.4	-3.7%	6.1%	62.3	51.6
Reported PAT Margin (%)	1.3%	1.2%	1.3%	-7bps	+3bps	4.0%	3.4%
Reported EPS (Rs.)	0.27	0.28	0.23	17.4%	-3.6%	2.89	2.35

*Note - Other Income includes Profit on Sale of Non-Core Assets of Rs. 458 lakhs for Quarter Ended 30th June, 2025, Rs.1009 lakhs for the year ended 31st March 2025.

GEOGRAPHICAL PRESENCE

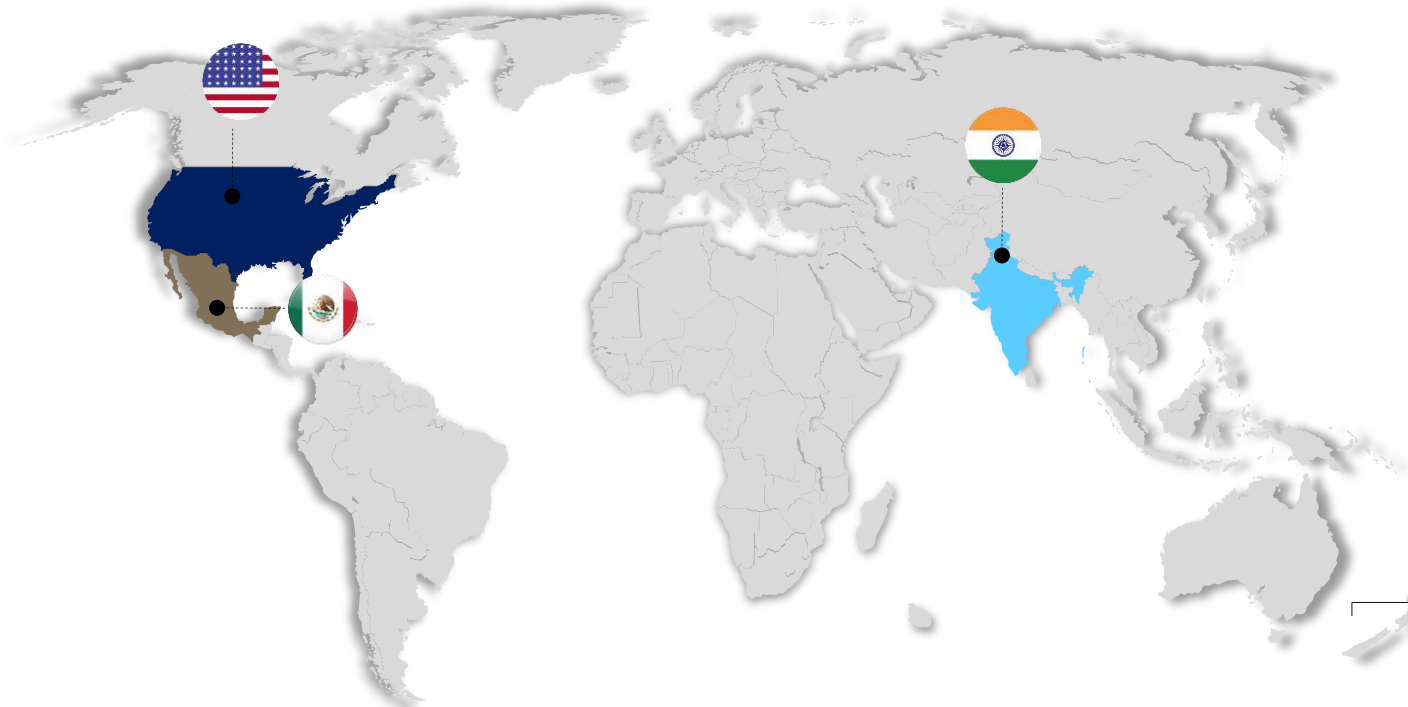

Geographical Sales Breakup %

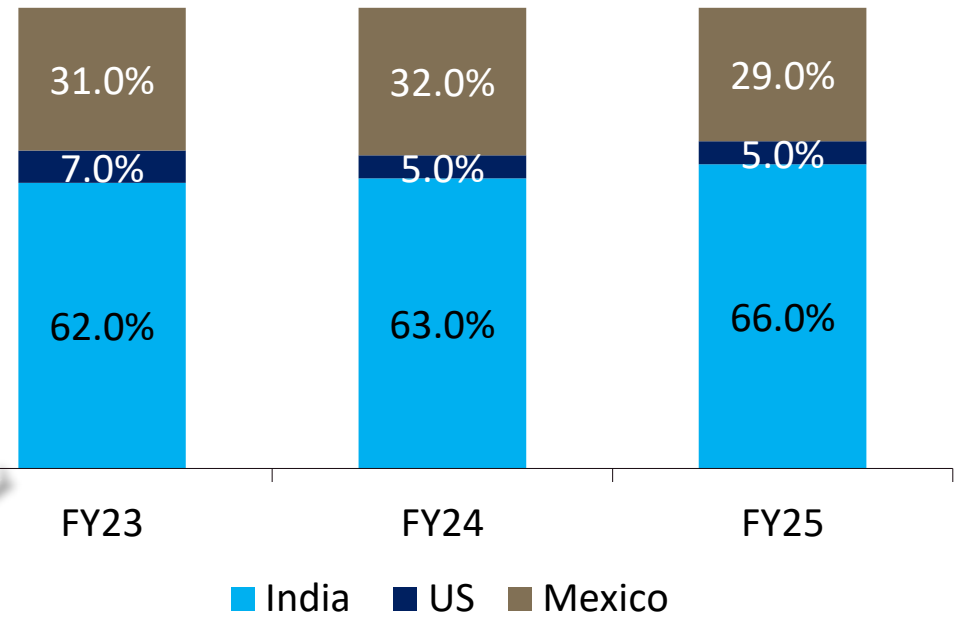

TOP CUSTOMER

Revenue from Top Customers (%)

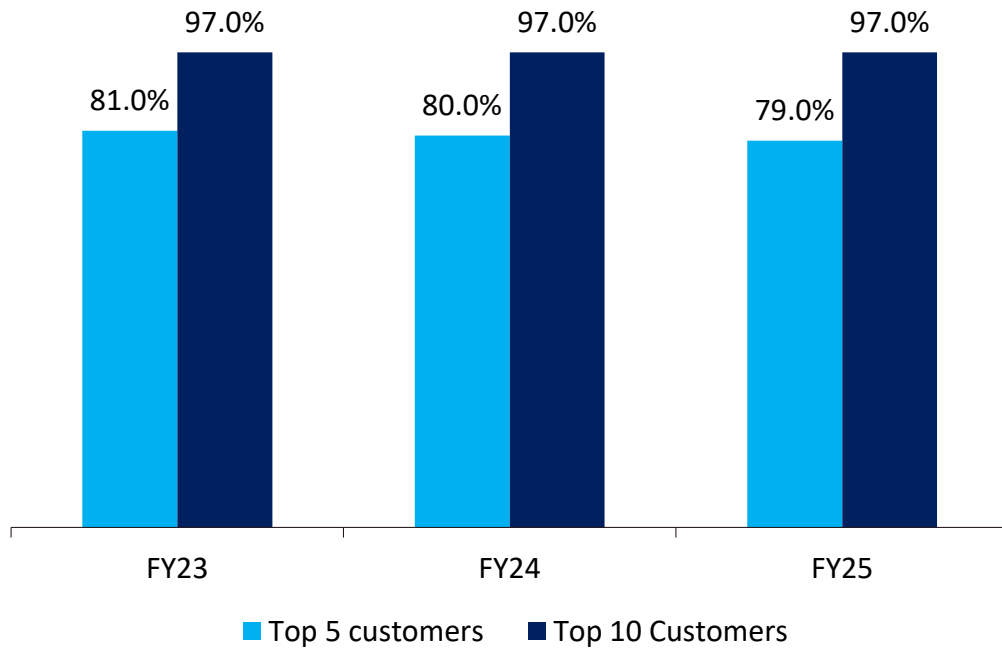

Segment wise sales Breakup (%)

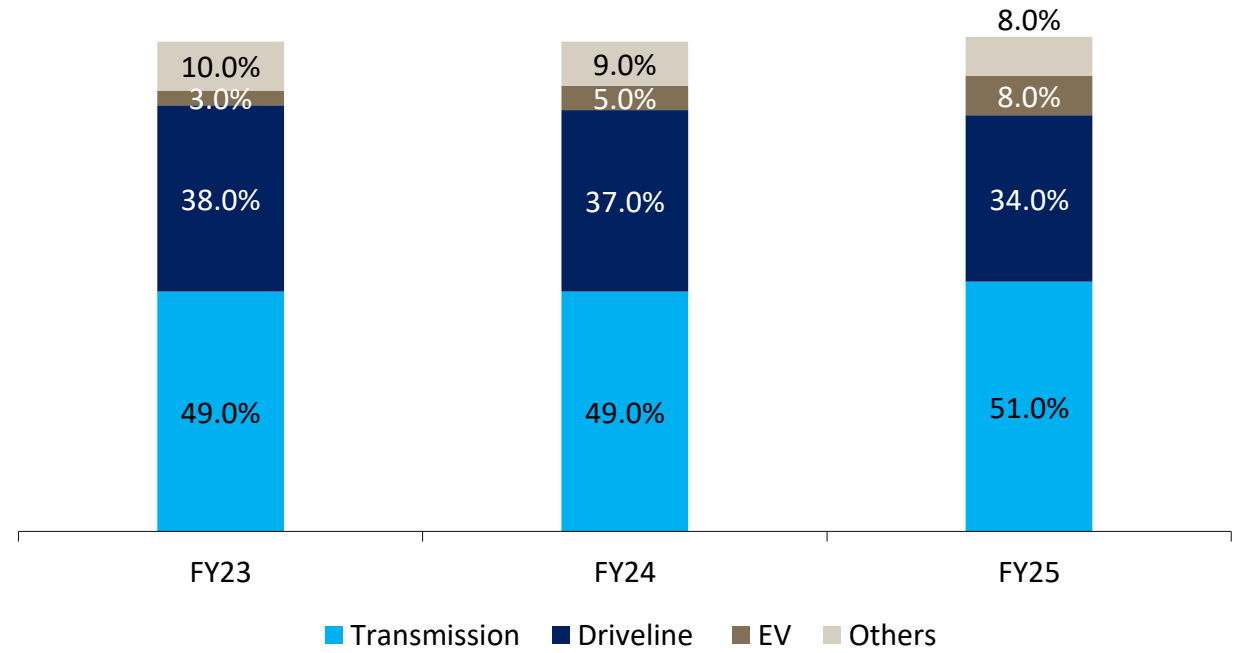

CONSOLIDATED KEY PERFORMANCE HIGHLIGHTS

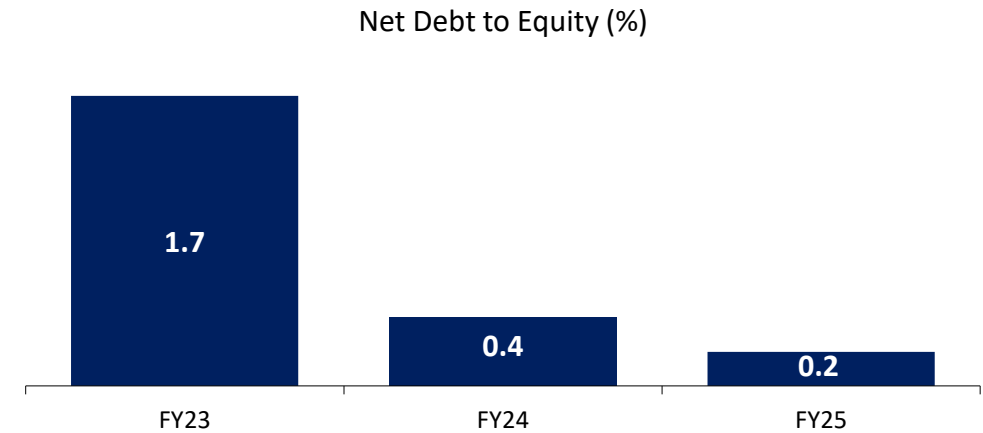
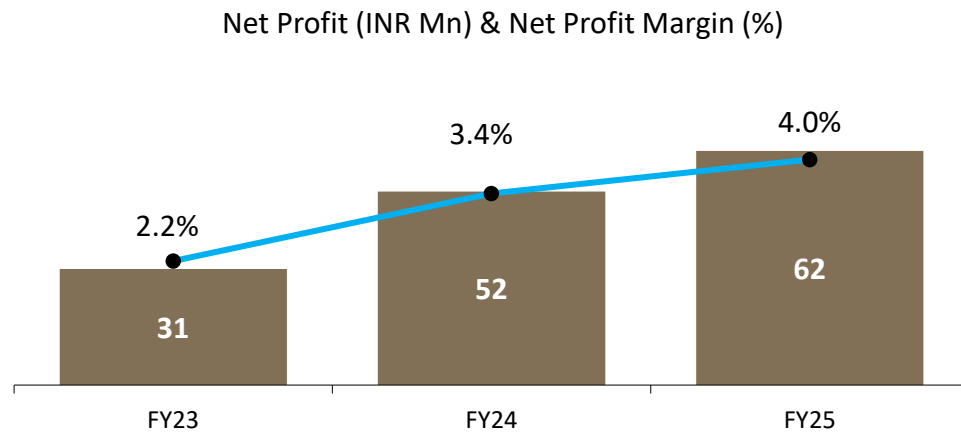
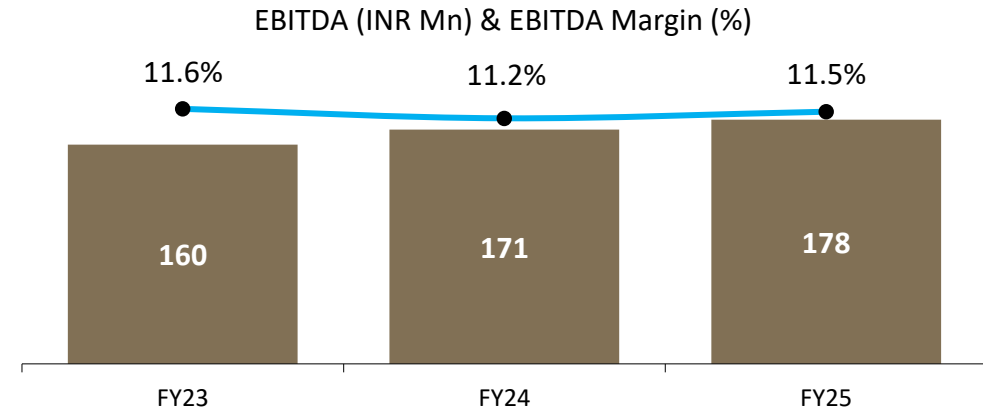
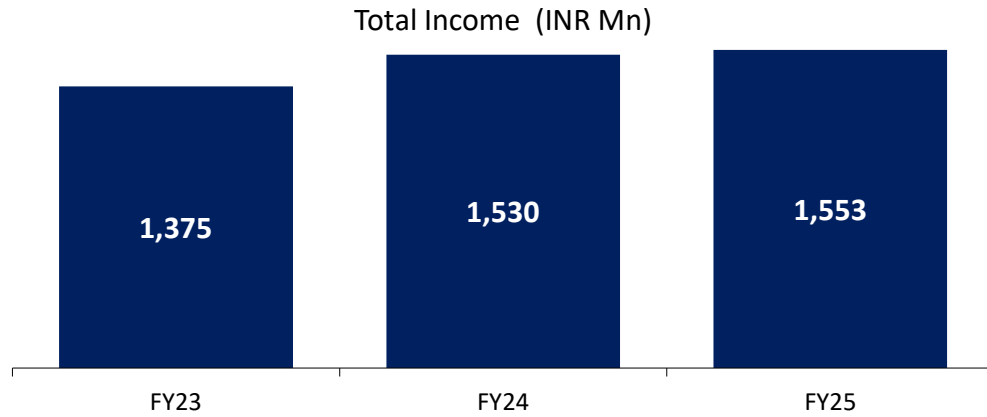

WAY FORWARD



UPCOMING PARTS OF EV

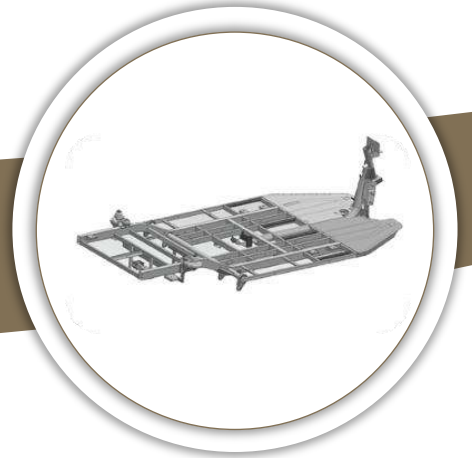
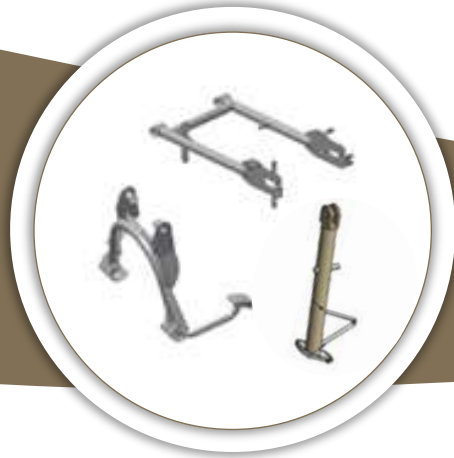

FRAMES & OTHER BODY PARTS

KEL makes **chassis, frames and body parts** such as side stand , rear forks, swing arms, main stands for **2-wheeler and 3-wheelers** and supplies them duly welded and painted.

INDIA'S GROWING AUTO COMPONENT MARKET



Indian Auto Component Industry:

- Contributes ~2.3% to India's GDP and employs 1.5 million+ people directly.
- Industry revenue projected to exceed USD 80.1 billion by FY25 (ACMA).
- Driven by strong domestic demand, rising exports, and EV transition.
- EV adoption is a key growth catalyst, boosting component innovation & investments.

Current Market Size:

In FY24, the industry achieved a turnover of **(\$74.1 Billion)**, marking a **9.8%** increase from the previous year.

Key Growth Drivers:

1

Rising Domestic Demand:

Increased sales of larger vehicles, such as utility vehicles (UVs), and higher-capacity motorcycles are boosting component demand.

2

EV Component Growth:

The contribution of EV components doubled to 6% of total production in FY24, reflecting the rapid adoption of electric vehicles.

3

Technological Advancements:

Investments in new technologies, including EV components and advanced manufacturing processes, have enhanced the industry's global competitiveness.

4

Localization & Value Addition:

Efforts to localize production and enhance value addition have contributed to the industry's growth, reducing dependency on imports and improving cost competitiveness.

5

Government Initiatives:

Policies such as the Production Linked Incentive (PLI) scheme and the Automotive Mission Plan aim to boost domestic manufacturing, encourage innovation, and attract investments in the auto component sector.

Source: [IBEF](#)

ANNUAL FINANCIALS



ANNUAL INCOME STATEMENT

Particulars (INR Mn)	Standalone		Consolidated		
	FY21	FY22	FY23	FY24	FY25
Net Sales	838.7	1,215.6	1,353.8	1,439.3	1,424.6
Other Income	31.7	27.9	21.3	90.4	128.1
Total Income	870.3	1,243.5	1,375.1	1,529.7	1,552.7
Cost of Raw material Consumed	445.2	695.5	763.3	837.2	784.1
Changes in Inventory	-10.0	-54.6	-53.9	-46.3	-9.5
Employee Benefits	173.8	191.3	190.4	214.1	224.0
Other expenses	191.4	267.2	315.8	354.1	375.9
Total Expenditure	800.4	1,099.4	1,215.6	1,359.1	1,374.5
EBITDA	69.9	144.1	159.5	170.6	178.2
EBITDA Margin (%)	8.0%	11.6%	11.6%	11.2%	11.5%
Depreciation	67.8	64.7	64.8	64.5	66.9
PBIT	2.1	79.4	94.7	106.1	111.3
Interest	64.4	65.8	63.9	54.5	49.0
PBT	-62.3	13.6	30.9	51.5	62.3
Tax	-	-	-	-	-
Reported Net Profit	-62.3	13.6	30.9	51.5	62.3
Reported PAT Margin (%)	-7.4%	1.1%	2.2%	3.4%	4.0%
Reported EPS (Rs.)	-3.45	0.82	1.54	2.35	2.89

ANNUAL CONSOLIDATED BALANCE SHEET

Particulars (INR Mn)	FY23	FY24	FY25
Equity & Liabilities			
Equity			
Share Capital	198.8	221.6	234.1
Reserves and surplus	88.1	376.4	796.9
Non Controlling Interest	2.0	44.5	142.6
Total Equity	288.8	642.5	1,173.6
Non-Current Liabilities			
Financial Liabilities			
i) Borrowing	228.7	290.9	437.1
Provisions	25.7	19.8	17.7
Other Non-current Liabilities	110.7	52.7	0.0
Total Non-Current Liabilities	365.1	363.4	454.9
Current Liabilities			
Financial Liabilities			
i) Borrowings	298.9	42.1	166.4
ii) Trade Payables	425.4	421.6	401.5
iii) Other	73.1	70.3	36.4
Other Current Liabilities	77.2	185.5	104.2
Short-term Provisions	40.4	34.0	29.5
Total Current Liabilities	914.9	753.5	738.0
Total Equity & Liabilities	1,568.9	1,759.4	2,366.4

Particulars (INR Mn)	FY23	FY24	FY25
Non-Current Assets			
Property Plant & Equipment	645.8	634.7	579.3
Other Intangible asset	2.5	2.0	3.9
Capital Work in progress	16.0	47.2	384.7
Financial Assets			
i) Investments	46.9	88.6	38.5
ii) Other	35.1	32.7	32.5
Other Non-current Assets	10.1	7.3	6.0
Total Non-Current Assets	756.4	812.6	1,045.0
Current Assets			
Inventories	442.8	510.2	540.9
Financial Assets			
i) Investments	-	-	-
ii) Trade Receivable	293.3	315.4	376.0
iii) Cash and Cash Equivalent	29.2	96.8	378.0
iv) Loans	0.4	0.4	0.4
v) Other	0.4	0.3	0.1
Current Tax Asset	4.1	6.2	16.5
Other current assets	42.3	17.6	9.6
Total Current Assets	812.5	946.9	1,321.4
Total Assets	1,568.9	1,759.4	2,366.4

AWARDS & ACCOLADES



ICONIC BRAND AWARD

India's iconic brand 2025
PRIDE OF INDIA CONCLAVE
(ET NOW)



MANUFACTURING TODAY

NEXT GENERATION LEADER



RENAULT QUALITY AWARD

Best Supplier Quality



TV 9 AWARDS 2021

Company of the Year 2021 (Auto
& Auto Components)



EPC AAWARD

Export excellence award

THANK YOU

LETS FORGE
A KINETIC BOND!

KINETIC ENGINEERING LIMITED

Kinetic Innovation Park, D-1 Block Plot No. 18/2, MIDC Chinchwad
Pune – 411 019

Tel: 020-66142049

Email: kelinvestors@kineticindia.com

Website: www.kineticindia.com

KAPTIFY® Consulting

Strategy & Investor Relation | Consulting

Tel: +91 845 288 6099

Email: contact@kaptify.in

Website: www.kaptify.in

